

Making Rightward Scrambling Possible*

Yuji TAKANO

Theories of movement are closely tied to theories of phrase structure. As a result, it is often the case that a new conception of phrase structure makes possible a new approach to movement phenomena that resolves problems with earlier approaches. To the extent that the new approach is successful, it lends support to the new conception of phrase structure on which it is based.

This article attempts to make a contribution in this direction, in the empirical domain of rightward scrambling. To understand the nature of rightward scrambling, I will take up and examine postposing phenomena in Turkish. The examination of those phenomena reveals (i) that Turkish postposing is derived by rightward scrambling (rather than by a derivation involving only leftward movement) and (ii) that rightward scrambling, while sharing a number of properties with leftward scrambling, nevertheless behaves differently from it in important ways. Those differences are unexpected and hence hard to explain under traditional approaches to rightward scrambling appealing to rightward adjunction. To resolve this problem, I will propose a novel approach to rightward scrambling, pursuing the idea that Universal Grammar (UG) allows what I will call complement-forming movement, a movement operation in which an element moves and merges with a head to form the head's (new) complement rather than its Spec. I will argue that complement-forming movement is an instance of the "tucking-in" operation proposed by Richards (1997, 2001) and is to be expected under the minimalist view of phrase structure and derivation. I will show that once rightward scrambling is analyzed as complement-forming move-

*For comments and discussions on the work presented here, I would like to thank Jun Abe, Hiroshi Aoyagi, Gülşat Aygen, Phil Branigan, AslıGöksel, Cem Keskin, Murat Kural, Tom Leu, Mikinari Matsuoka, Shigeru Miyagawa, Takashi Munakata, Toshifusa Oka, David Pesetsky, Norvin Richards, Mamoru Saito, Daiko Takahashi, Masanobu Ueda, and Akira Watanabe. Portions of this paper were presented in talks at Kanda University of International Studies, Kwansai Gakuin University, and Tohoku Gakuin University, at the 55th Chubu Branch Meeting of the English Literary Society of Japan and the 76th General Meeting of the English Literary Society of Japan, and in my lectures at the 2005 Summer Linguistic Institute of the Linguistic Society of America (MIT). I would like to thank the audiences for questions and comments. The research reported here was supported by Kinjo Gakuin University Special Research Subsidy.

ment, the properties of Turkish postposing can be made to follow from an interaction of the properties of complement-forming movement and independently motivated principles and assumptions.

This article is organized as follows. In section 1, I will examine the properties of Turkish postposing and review a traditional approach in which rightward scrambling is analyzed as involving rightward adjunction. I will point out that this approach faces serious empirical problems. In section 2, I will propose an alternative approach to rightward scrambling, pursuing the idea that a moved element can merge with a head to form its complement. Then in section 3, I will show how this approach can explain the properties of Turkish postposing. In section 4, I will deal with another issue related to Turkish postposing. In section 5, I will conclude the discussion.

1 Postverbal Constituents in Turkish

1.1 Turkish PVCs Are Derived by Rightward Scrambling

The unmarked word order of a Turkish sentence is SOV. However, as is often the case with SOV languages, Turkish has leftward scrambling, which moves a preverbal constituent leftward, yielding variation of word order among preverbal elements. In addition, Turkish allows a constituent to appear after the verb. An example of this phenomenon is given in (1b).

- (1)a. Ahmet öğrencilerle konuştu.
 Ahmet students.with spoke
 'Ahmet spoke with the students.'
- b. Ahmet konuştu öğrencilerle.
 Ahmet spoke students.with (Kural 1997)

(1a) illustrates the unmarked word order. (1a) and (1b) mean the same, except that the postverbal constituent (PVC) in (1b) (*öğrencilerle*) is interpreted as backgrounded material, namely, as material whose denotation is part of the context assumed by the speaker and the listener in a given situation (Kural 1997:499).

Kural (1997) claims that Turkish PVCs are derived by rightward scrambling. This claim is supported by the fact that PVCs share important properties with elements scrambled leftward. First, leftward scrambling, being an instance of movement, obeys island constraints. The examples in (2) illustrate this.

- (2)a. *Ayşe-yeḡ ben [[Ahmet-in tḡ verdiḡi] kitab]-ı sevdim.
 Ayşe-Dat I Ahmet-Gen gave book-Acc liked
 'I liked the book that Ahmet gave to Ayşe.'
- b. *pasta-yı ben [Ahmet tḡ yediḡi için] sana kızdım.'
 cake-Acc I Ahmet ate for you.Dat angered
 'I got angry with you because Ahmet ate the cake.'

(2a) involves movement out of a relative clause and (2b) movement out of an adjunct clause. The examples in (3), from Kural 1997, are parallel to those in (2), except that they contain

PVCs instead of elements scrambled leftward.

(3)a. *pro [[Ahmet-in t_i verdiği] kitab]-₁ sevdim Ayşe-yej.

(I) Ahmet-Gen gave book-Acc liked Ayşe-Dat

'I liked the book that Ahmet gave to Ayşe.'

b. *pro [Ahmet t_i yediği için] sana kızdım pasta-y₁i.

(I) Ahmet ate for you angered cake-Acc

'I got angry with you because Ahmet ate the cake.'

The ungrammaticality of these examples strongly suggests that PVCs are derived by movement.

Second, just as more than one constituent can be scrambled leftward, more than one constituent can be postposed. Compare (4) and (5), both taken from Kornfilt 1997.

(4) Kitab-₁ Ali-ye Hasan dün verdi.

book-Acc Ali-Dat Hasan yesterday gave

'Hasan gave the book to Ali yesterday.'

(5) Kitab-₁ verdi Hasan Ali-ye.

book-Acc gave Hasan Ali-Dat

In this respect, Turkish leftward scrambling and postposing contrast with English topicalization:

(6) *The book, to Mary, John gave.

Finally, leftward scrambling can move a negative polarity item, as shown in (7b). Similarly, the postverbal material can be a negative polarity item, as shown in (7c) ((7a, b) from Kural 1997).

(7)a. Ahmet [kimse-nin uyumadığı₁]-₁ biliyor.

Ahmet anyone-Gen sleep.Neg-Acc know

'Ahmet knows that no one slept.'

b. Kimse-ninj Ahmet [t_i uyumadığı₁]-₁ biliyor.

anyone-Gen Ahmet sleep.Neg-Acc know

c. (?)Ahmet [t_i uyumadığı₁]-₁ biliyor kimse-ninj.

Ahmet sleep.Neg-Acc know anyone-Gen

This is also a property not shared by English topicalization:

(8) *Anyone, I didn't see.

Given that postposing shares these properties with leftward scrambling, it is reasonable to assume with Kural (1997) that Turkish PVCs are derived by rightward scrambling.¹⁾

1) Kornfilt (1996) proposes that what moves rightward in Turkish postposing is an appositive parenthetical expression, on a par with *the cops* in the English example in (i).

(i) They, the cops, spoke to the janitor yesterday.

Kornfilt claims that the Turkish PVC arises when the real argument with which the appositive parenthetical is construed (*they* in the case of (i)) is a pro. Kornfilt's proposal is motivated by discourse properties exhibited by Turkish PVCs. In this article, I follow Kural (1997) in treating PVCs as arguments.

1.2 The Rightward Adjunction Approach

Given that Turkish PVCs involve rightward scrambling, the next question to ask is how this idea is implemented theoretically. One popular approach has been to assume that rightward scrambling involves rightward adjunction to some projection (Kennelly 1996, Kornfilt 1996, Kural 1997). For instance, Kennelly (1996) and Kural (1997) analyze PVCs as elements right-adjoined to CP. On this analysis, a sentence with a PVC will have the structure in (9).

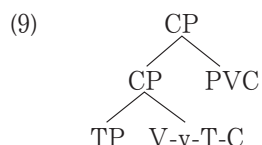

Kural (1997) proposes that the verb always raises overtly to C in Turkish and that, due to this verb raising, PVCs can only be adjoined in the domain of C (adjunction in a lower domain does not yield postverbal order). If leftward scrambling involves leftward adjunction (Saito 1985), PVCs receive a parallel treatment to leftward scrambling under this analysis.

The rightward adjunction approach to Turkish PVCs faces problems, however. Specifically, it cannot properly account for the scope properties of PVCs, discussed in detail by Kural (1997). Let us first look at the basic patterns of scope taking in Turkish clauses without PVCs. Consider (10), where both the subject and the object are quantificational phrases (QPs).

(10)a. SU OB V.

Üç kişi herkes-i dün aramış. [SU > OB, *OB > SU]
 three person everyone-Acc yesterday called
 'Three people called everyone yesterday.'

b. OB SU V.

Herkes-i üç kişi dün aramış. [OB > SU, *SU > OB]
 everyone-Acc three person yesterday called

Kural (1997) observes that in Turkish, under neutral intonation, the scope order of QPs matches their surface linear order. Thus, in (10a), where the subject precedes the object, the former unambiguously takes scope over the latter, whereas in (10b), where the object precedes the subject, only the opposite scope order is available.

The generality of this pattern of scope taking in Turkish can be ensured by examining cases having two QPs that are internal arguments of a verb, as in (11) and (12).

(11)a. SU DAT ABL V.

Ahmet üç kişi-ye her kitap-tan sözetti. [DAT > ABL, *ABL > DAT]
 Ahmet three person-Dat every book-Abl mentioned
 'Ahmet talked to three people about every book.'

b. SU ABL DAT V.

Ahmet her kitap-tan üç kişi-ye sözetmiş. [ABL > DAT, *DAT > ABL]
 Ahmet every book-Abl three person-Dat mentioned

(12)a. DAT ABL SU V.

Üç kişi-ye her kitap-tan Ahmet sözetmiş. [DAT > ABL, *ABL > DAT]
 three person-Dat every book-Abl Ahmet mentioned

b. ABL DAT SU V.

Her kitap-tan üç kişi-ye Ahmet sözetmiş. [ABL > DAT, *DAT > ABL]
 every book-Abl three person-Dat Ahmet mentioned

In (11) the two internal arguments are located between the subject and the verb. In each case, as expected, the preceding internal argument takes scope over the following one. In (12) both internal arguments are scrambled in front of the subject, but the scope-taking pattern remains the same as in the previous cases.

At first sight, the cases we have seen so far seem to suggest that scope is a linear phenomenon in Turkish, in the sense that scope relations can be determined only in terms of the linear order of QPs. But PVCs refute this simple analysis in an interesting way. Consider (13).

(13)a. SU V OB.

Üç kişi dün aramış herkes-i. [OB > SU, *SU > OB]
 three person yesterday called everyone-Acc
 'Three people called everyone yesterday.'

b. OB V SU.

Herkes-i dün aramış üç kişi. [SU > OB, *OB > SU]
 everyone-Acc yesterday called three person

In each case in (13) either the subject or the object appears as a PVC. Kural (1997) reports that in these cases the PVC unambiguously takes scope over the preverbal QP.²⁾ This clearly shows that the linear account fails: in (13) the following QP takes wider scope than the preceding QP.

Let us assume, as is standard, that scope relations are determined by hierarchical (c-command) relations holding between QPs. Then, as Kural (1997) claims, the scope facts in (10)-(12) indicate that in Turkish, scope relations are solely determined by c-command relations obtaining in the syntactic structure at Spell-Out, with the derivation from Spell-Out to LF not assigning new scope. On this view, the scope facts in (13) are interpreted as showing that the PVC is necessarily located in a position c-commanding preverbal material. The rightward adjunction approach to Turkish PVCs can account for this property if the PVC is always adjoined to CP, as Kural (1997) argues.

A problem arises, however, with the treatment of preverbal QPs. Recall that on Kural's (1997) analysis, the verb always raises overtly to C in Turkish. Assuming this, imagine

2) Although Kural (1997) judges the examples in (13) unambiguous, Kornfilt (1996) observes that there are speakers, including herself, who find examples like (13a) ambiguous. I will return to this point in section 3.1.

that the subject is right-adjoined to TP, whereas the object stays in VP. This gives rise to the following structure (here and in what follows, material in angled brackets indicates a copy of the moved element):

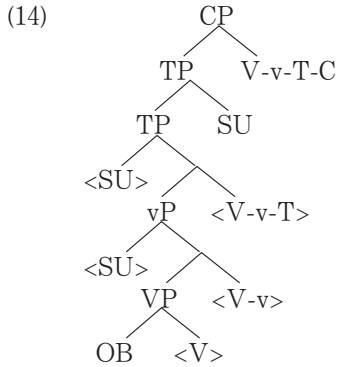

This structure would yield the surface order OB-SU-V. So if this structure were available, (10b) should have a wide scope reading of the subject, contrary to fact.

The same kind of problem arises for (11), where the two internal arguments of the verb are QPs. In this case, the following internal argument could be right-adjoined to a projection higher than the preceding one but lower than CP. Imagine that the dative phrase in (11b) is right-adjoined to vP or TP. Such a structure wrongly predicts ambiguity for this sentence.

These problems stem from Kural's (1997) claim that the verb raises to C. If the verb stays in place, rightward adjunction of an argument never produces a verb-final sentence and therefore, the same problems do not arise.

A different kind of problem for the rightward adjunction approach is caused by multiple PVCs. Relevant examples are given in (15).

(15)a. V SU OB.

Dün aramış üç kişi herkes-i. [SU > OB, OB > SU]
 yesterday called three person everyone-Acc
 'Three people called everyone yesterday.'

b. V OB SU.

Dün aramış herkes-i üç kişi. [SU > OB, OB > SU]
 yesterday called everyone-Acc three person

Kural (1997:note 17) observes that cases like those in (15) are ambiguous, allowing both the subject and the object to take wide scope regardless of the linear order of the two PVCs. This is a surprising fact, given that the Turkish examples we have examined so far never show such scope ambiguity.

Kural (1997) suggests an analysis of this fact that makes reference to a special property of adjunction structure. Let us consider (16), which we take to be the structure of the example in (15a) under the rightward adjunction approach.

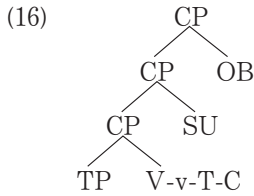

There is no doubt that the postverbal object c-commands the postverbal subject in this structure. This accounts for the OB > SU reading. The other reading will also follow if the CP segment immediately dominating the postverbal subject does not count in defining its c-command domain. In that case, the postverbal subject c-commands the postverbal object following it, which will account for the SU > OB reading.

Although it works for the cases in (15), this analysis raises a serious question in a broader context. To see why, let us observe (17), where the two PVCs are both internal arguments.

(17)a. SU V DAT ABL.

Ahmet söz-etmiş üç kişi-ye her kitap-tan. [DAT > ABL, ABL > DAT]

Ahmet mentioned three person-Dat every book-Abl

b. SU V ABL DAT.

Ahmet söz-etmiş her kitap-tan üç kişi-ye. [ABL > DAT, DAT > ABL]

Ahmet mentioned every book-Abl three person-Dat

Just like the examples in (15), the examples in (17) are ambiguous. Moreover, they indicate clearly that rightward scrambling behaves differently from leftward scrambling. Recall that the sentences in (12a, b), which involve leftward scrambling of the two internal arguments, are unambiguous. If rightward scrambling is analyzed as rightward adjunction, there is no principled reason to exclude the possibility that leftward scrambling is carried out by leftward adjunction. And if the ambiguity seen in (17) is due to a special property of adjunction structure, there is every reason to expect the same result for the cases in (12). Since this expectation is not fulfilled, the account of the ambiguity in (15) and (17) that relies on adjunction structure cannot be correct. It appears that the rightward adjunction approach has nothing more to say about the scope ambiguity displayed by multiple PVCs.³⁾

Another challenge to the rightward adjunction approach can be seen when we consider a structural restriction on Turkish PVCs. Kural (1997) notes that PVCs are not allowed in embedded clauses. Look at the following examples:

(18)a. Ayşe [Ahmet-in öğrencilerle konuştuğun]-u biliyor.

Ayşe Ahmet-Gen students.with speak-Acc know

'Ayşe knows that Ahmet spoke with the students.'

3) Kornfilt (2005) also observes that multiple postposing as in (17) shows a different scope pattern from multiple scrambling as in (12). Although she does not claim that cases like (17) are ambiguous, she does point out that linear order between the two PVCs does not affect their relative scope, in sharp contrast with cases involving multiple scrambling. To capture this property of multiple PVCs, Kornfilt (2005) suggests that there is no hierarchical asymmetry between multiple PVCs. I will propose a different account later.

- b. Ayşe [Ahmet-in t_i konuştuğ_{un}]-u biliyor öğrencilerle.
 Ayşe Ahmet-Gen speak-Acc know students.with
- c. *Ayşe [Ahmet-in t_i konuştuğ_{un}]-u öğrencilerle biliyor.
 Ayşe Ahmet-Gen speak-Acc students.with know
- d. Ayşe [öğrencilerle Ahmet-in t_i konuştuğ_{un}]-u biliyor.
 Ayşe students.with Ahmet-Gen speak-Acc know

(18a) shows the unmarked order of a sentence containing an embedded clause that is a complement of the matrix verb. In (18b) the object of the embedded verb appears as a PVC in the matrix clause. If the same element appears as a PVC in the embedded clause, that is, if it surfaces between the matrix verb and the embedded verb, the sentence is ungrammatical, as shown in (18c). The same restriction is not attested with leftward scrambling in Turkish, as evidenced by the grammaticality of (18d).

Under the rightward adjunction approach, there seems to be nothing wrong with adjoining an element to an embedded CP. This constitutes an initial difficulty. One way to block (18c) is to assume that rightward adjunction is restricted to CP and that the embedded clause in (18c) is a DP rather than a CP (Kennelly 1996). The latter assumption may be supported by the following facts about the embedded clause in (18): the verb takes nominal, instead of verbal, morphology (*tuğ* in *konuştuğ_u* is a nominalizing morpheme), the subject is in the genitive instead of nominative (the subject takes genitive case in DPs in Turkish), and the embedded clause has an accusative case particle attached to it. However, this account leaves unanswered the very important question of why rightward adjunction is restricted to CP. As it stands, it does not give us any insight into the nature of the prohibition against embedded PVCs.

Kornfilt (1996) proposes an alternative account. Following Chomsky (1986), she argues that adjunction be allowed only to nonarguments. Given that the embedded clause in (18) is an argument, the ungrammaticality of (18c) follows on this analysis, regardless of the categorial status of the embedded clause. So this alternative seems to work for cases like (18c), except that the question remains why adjunction to arguments is prohibited (see Chomsky 1986 for some discussion).⁴⁾

A more serious question arises, given the fact that PVCs are not always impossible within an argument clause. Erguvanlı (1984) reports the following contrast (see also Kennelly 1996 and Kornfilt 1996):

- (19)a. *Erol [Ali-nin t_i döndüğ_{ün}]-ü Ankara-dan bil-mi-yor.
 Erol Ali-Gen return-Acc Ankara-Abl know-Neg-Prog
 'Erol doesn't know that Ali returned from Ankara.'
- b. Ben [t_i o kız-ı tan-ı-yor] Ali zannettim.
 I that girl-Acc know-Prog Ali thought
 'I thought that Ali knew that girl.'

4) Kural (1997) suggests a similar account, though in terms of prohibition against adjunction to a category that is in a Case-checking position.

Both examples in (19) contain an embedded PVC but only (19a) is ungrammatical. The crucial difference between (19a) and (19b) seems to lie in the nature of the embedded clause: the embedded clause is nominal in (19a) but not in (19b). Like the embedded clause in (18), the embedded clause in (19a) has a case particle suffixed to it. The verbs of these embedded clauses are morphologically nominalized (*tug̃* in (18) and *duḡ* in (19a) are nominalizing morphemes) and do not show the tense inflection that the verbs of fully tensed clauses do. And the subjects of the embedded clauses in (18) and (19a) are both genitive. On the other hand, the verb of the embedded clause in (19b) does not take nominal morphology and shows the tense inflection of fully tensed clauses. Moreover, in (19b) the embedded clause is not accompanied by a case particle and its subject is nominative.

The contrast between (19a) and (19b) seems to represent a general pattern. On the basis of examination of embedded PVCs in a wide variety of constructions, Erguvanlı (1984:113) reached the following generalization:

(20) Embedded PVCs are blocked in nominal clauses.

If PVCs are indeed allowed in embedded clauses that are not nominal, as predicted by this generalization, it cannot be captured by the rightward adjunction approach (see, however, Kornfilt 1996 for a different treatment of cases like (19b)).

To sum up the discussion so far, we have seen the following properties associated with Turkish rightward scrambling:

(21)a. An element that has undergone rightward scrambling necessarily takes scope over preverbal material.⁵⁾

b. Unlike multiple leftward scrambling, multiple rightward scrambling yields scope ambiguity.

c. Unlike leftward scrambling, rightward scrambling is blocked in nominal clauses.

We have also seen that the rightward adjunction approach cannot account for these properties without causing problems.

One might wonder if these properties fall into place under the antisymmetric approach to syntax put forth by Kayne (1994, 1998), according to which syntax does not allow rightward movement at all. In fact, (21b) provides a strong argument against such an approach to syntax. Under such an approach, the examples in (17a, b) would be derived by three applications of leftward movement. The following shows a derivation for (17a) compatible with Kayne's (1998) view:

(22) SU DAT ABL V. → leftward movement of ABL
 ABL_i SU DAT t_i V. → leftward movement of DAT
 DAT_j ABL_i [x SU t_j t_i V]. → leftward movement of X
 [x SU t_j t_i V]_k DAT_j ABL_i t_k.

As we can see, the derivation in (22) involves only leftward movement, and the surface order of (22d) matches that of (17a). But crucially, this analysis cannot capture the scope

5) See also Kornfilt 1996, 2005 for other evidence not based on quantifier scope that Turkish PVCs are structurally higher than preverbal material.

ambiguity that the sentence in (17a) exhibits. Given that DAT and ABL both undergo leftward movement in the derivation illustrated in (22), it predicts wrongly that the sentence in (17a) should be identical to the sentence in (12a), where the two internal arguments are scrambled leftward, with respect to scope properties (the difference between (22) and the derivation of (12a) is only that (22) involves the additional step of movement of X, which is highly unlikely to affect the scope relation between DAT and ABL). The fact that (17a) is ambiguous, in contrast to (12a), thus undermines the approach that analyzes (17a) in the way shown in (22). The same argument holds for (17b) vs. (12b).⁶⁾

What is needed is thus an analysis in which Turkish PVCs are derived by some form of rightward movement that is, however, not carried out by rightward adjunction.

2 A Proposal

2.1 Complement-Forming Movement

To provide an alternative analysis of Turkish PVCs, I explore a new possibility for movement. First of all, I assume that Turkish is strictly head-final, in the sense that a head necessarily surfaces as the final element within its maximal projection. This means that both complement and Spec of a head appear to the left of the head. I also follow Kural (1997) in analyzing Turkish PVCs as resulting from scrambling. But I adopt the position that all movement, including scrambling, involves simple Merge (Set-Merge in Chomsky's (2000) terms) and not adjunction. This ensures, contrary to Kural's claim, that rightward adjunction is not an option for the analysis of Turkish PVCs. On the other hand, I remain neutral here as to whether adjunction exists as an additional operation that introduces adjuncts into the derivation, which is an issue orthogonal to the main discussion that follows.

Keeping this set of assumptions in mind, suppose that scrambling moves an element to the domain of C. The standard case is one where the scrambled element moves to Spec,C. Prior to movement, the structure will be something like (23).

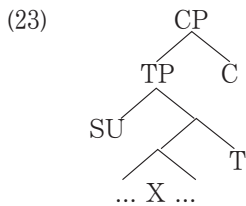

After scrambling of X, the new structure in (24) is formed.

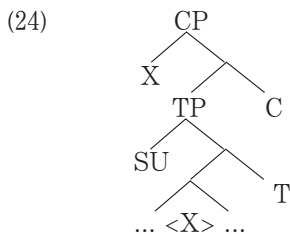

6) See also Kural 1997 and Kornfilt 1996, 2005 for arguments based on Turkish PVCs against Kayne's (1994) analysis of postposing phenomena.

This scrambling results in leftward movement.

Note that under the minimalist theory of phrase structure, according to which syntactic structure is built up by successive application of the elementary operation Merge (Chomsky 1995 and subsequent work), scrambling of X in (24) is not so much movement into a Spec position as movement forming a Spec; that is, X does not substitute for anything in this model. In other words, all movement is carried out in this model by picking an element internal to the existing structure S and merging it with S. Chomsky (2001) calls this kind of Merge internal Merge, as opposed to external Merge, which merges two independent elements.

In the case of (23)/(24), merger of X and CP extends the structure (X in (24) is external to the CP in (23)). Richards (1997, 2001) proposes that internal Merge does not always extend the structure. More specifically, he claims that in multiple *wh*-movement, a Spec of C having a *wh*-phrase always becomes a higher Spec when another *wh*-phrase moves to form another Spec of C. The situation is illustrated in (25).

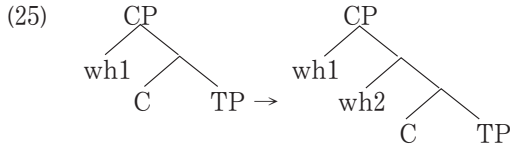

In other words, on this analysis, the second *wh*-phrase "tucks in" beneath the first *wh*-phrase in CP.

Once we accept this form of internal Merge, another logical possibility emerges. Imagine that scrambling to the domain of C can form not only a Spec of C but a complement of C as well. This means that scrambling of X in (23) can create the structure in (26), as well as the structure in (24).

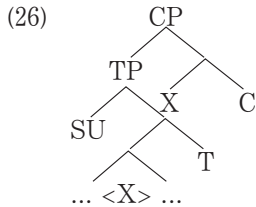

Given the strictly head-final structure, and assuming that the verb stays in place, X in (26) surfaces following the verb. Note also that C is phonetically null in Turkish. This ensures that X is final in the sentence. I propose that this is how Turkish PVCs are derived.

Scrambling of X in (26) has the effect of merging X and C, forming a new constituent made up of the head C and its new complement X. Thus, it is an instance of *complement-forming movement*. In earlier theories, this kind of movement was regarded as movement into a position selected by a head and was barred by the Projection Principle. Given that C subcategorizes for TP, the Projection Principle requires the complement position of C to be filled at D-structure and hence there is no complement position for X to move into. In minimalism, however, movement (internal Merge) creates a position, so the same problem

does not arise, and complement-forming movement should in principle be possible, just like Spec-forming movement. I also claim that this is a natural extension of the idea of tucking-in movement proposed by Richards (1997, 2001): while Richards's tucking in creates a lower Spec position internal to the existing structure S, complement-forming movement creates a new complement position internal to S.

However, complement-forming movement is nevertheless nonstandard in three respects and we need to address the concerns that arise from them. First, TP, which C subcategorizes for, becomes a Spec of C as a result of movement of X. Second, X becomes a complement of C even though C does not subcategorize for X. Third, the movement creates a chain whose head does not c-command its tail (in (26) X does not c-command $\langle X \rangle$). Although they seem to constitute problems with my proposal, I argue that the problems are only apparent. Specifically, I will claim that the first two points cease to be problematic under the derivational approach to syntactic relations that is adopted in much current work conducted within the Minimalist Program. I will also show that the third concern can be resolved by adopting Chomsky's (1995, 2000) view of movement. Moreover, I will argue that complement-forming movement in fact falls under a class of nonstandard movements that Richards (2004) argues should be allowed by UG.

The first two concerns are the two sides of the same coin: TP becomes a Spec of C even though C subcategorizes for TP, and X becomes a complement of C even though C does not subcategorize for X. By its very nature, complement-forming movement creates a new head-complement structure, which changes the original complement into a Spec. In the case at hand, TP is the original complement of C but it becomes a Spec of C after scrambling of X. The question is why this is possible. The answer to this question lies in a derivational approach to syntactic relations adopted in much current work (see Epstein et al. 1998 for extensive discussion of this approach). What is relevant here is a derivational approach to θ -relations. Lasnik (1995a), Bošković and Takahashi (1998), and Saito and Hoshi (2000) argue that θ -roles are formal features and that each θ -role is checked when Merge applies in the course of a derivation. A similar approach is implicit in Chomsky's (2000) treatment of θ -marking, too, though he does not consider θ -roles formal features. Chomsky claims that Merge, being a last resort operation, needs a driving force. According to Chomsky, one such driving force for external Merge is a θ -marking property of a head (an EPP feature is another that motivates movement, namely, internal Merge). Thus, Merge can apply to X and Y when one of them satisfies a θ -role of the other. This amounts to saying that θ -relations are satisfied derivationally each time a head with a θ -marking property merges with an argument. See also Bošković 1994, Hornstein 1999, and Saito 2003b for a derivational view of θ -relations.

Let us generalize this move to all selectional relations. In the present case, C subcategorizes for TP, another form of selection. Under the derivational approach, this selectional relation is satisfied when C and TP are merged. Therefore, complement-forming scrambling in (26) does not affect the relation satisfied derivationally between C and TP.

The same story holds for the second concern. As a result of complement-forming movement, X becomes a new complement of C even though C does not subcategorize for X. There is nothing wrong with this situation since the selectional relation between C and TP has already been satisfied (later I will adopt the position that scrambling is driven by an EPP feature of a functional head, so complement-forming scrambling to C satisfies an EPP feature of C).

Let us turn to the third concern. This has to do with the Proper Binding Condition (PBC), which requires traces to be bound (Fiengo 1977, May 1977, Saito 1989). Given that X does not c-command its copy in (26), the movement in question might be excluded by the PBC. However, the empirical validity of this condition has often been questioned on the basis of grammatical examples, such as the one in (27), in which an element containing a trace of another element undergoes movement, making the trace unbound (see Müller 1996, 1998 and Takano 1994 for relevant discussion).

(27) [How t_i likely to win] $_j$ is John $_j$ t_j ?

One important fact that the PBC is designed to capture is that lowering is generally prohibited. Thus, the following Japanese example, which involves scrambling to a lower position, is ungrammatical:

(28) *Ken-ga t_i [Masao-ga Yumi-ni $_j$ kuruma-o katta to] itta.
 Ken-Nom Masao-Nom Yumi-Dat car-Acc bought that said
 'Ken told Yumi that Masao bought a car.'

If the same element scrambles to a higher position, the resulting sentence is grammatical:

(29) Yumi-ni $_j$ Ken-ga t_i [Masao-ga kuruma-o katta to] itta.
 Yumi-Dat Ken-Nom Masao-Nom car-Acc bought that said

One way of blocking this kind of lowering is to appeal to the PBC: the trace is unbound in (28).

However, as pointed out by Richards (2004), the same effect can be achieved without the PBC if we adopt Chomsky's (1995, 2000) view of movement and cyclicity. Chomsky proposes that all movement be feature-driven, in the sense that movement of an element E to the domain of a head H takes place only when H has a relevant feature that attracts E (a strong feature for Chomsky (1995) and an EPP feature for Chomsky (2000)). Chomsky also proposes a feature-based approach to cyclicity. In this approach, all strong/EPP features of the head H must be satisfied as soon as possible (Chomsky 1995, Richards 1997, 2001). There are a number of ideas about the interpretation of "as soon as possible," the details of which do not concern us. For present purposes, let us assume that when H has a feature inducing movement, that feature must be satisfied before the maximal projection of H gets embedded (Chomsky 1995). Movement in (28) is then excluded since no head in the embedded clause can attract any element in the matrix clause without violating (feature-based) cyclicity. Thus, lowering can be excluded without the PBC.

Note that the complement-forming movement depicted in (26) does obey cyclicity interpreted this way. Prior to movement of X, the structure is (24). In this structure, C can

attract X in accordance with cyclicity, given that CP, the maximal projection of C, is the topmost constituent at this point of the derivation. What is needed to derive (26) is an extension of the standard assumption that when H attracts an element X, X merges at Spec, H; we now assume that X can merge anywhere in H's domain – not only at a Spec but also at a complement of H. This should in fact be a natural extension, given Chomsky's (2005:14) claim that there is no principled distinction between specifier and complement in the minimalist conception of phrase structure.

This account of (26) vs. (28) presupposes that scrambling has some driving force, contrary to the analysis of scrambling as non-feature-driven movement (Fukui 1993, Saito 1985, 2003a, Saito and Fukui 1998, Takano 1998). Here I follow Miyagawa (2001) and assume that scrambling is induced when a functional head has an EPP feature alone (i.e., without agreement features). I also assume that scrambling-inducing EPP features are optionally assigned to functional heads (which accounts for the optionality of scrambling).⁷⁾

Richards (2004), adopting the cyclicity-based approach to illicit cases of lowering discussed above, argues that lowering should in fact be permitted in cases where cyclicity is not violated. As evidence for this claim, he points out an interesting case of multiple *wh*-movement in Bulgarian that involves lowering but is still acceptable. The account he offers for this fact has an important consequence for the present proposal for complement-forming movement.

Let us first discuss standard cases of multiple *wh*-movement. Bulgarian is a multiple *wh*-movement language where all *wh*-phrases must move overtly to Spec,C. Moreover, there is a strict restriction on the surface order of *wh*-phrases that have undergone overt *wh*-movement (except when they are D-linked), to the effect that if the base position of a *wh*-phrase c-commands that of another *wh*-phrase, the c-commanding *wh*-phrase necessarily precedes the c-commanded one (Rudin 1988, Bošković 1997, 1999, Richards 1997, 2001). Thus, if a sentence contains a subject *wh*-phrase and an object *wh*-phrase, the former must precede the latter on the surface:

(30)a. Koj kogo vizda?

who whom sees

'Who sees whom?'

b. *Kogo koj vizda ?

Richards (1997, 2001) proposes that this fact follows from a locality condition that constrains relations between all the participants in a movement dependency, namely, the attractor and the head and the tail of the chain formed by movement. Richards calls this condition Shortest. (31) is a version of Shortest adopted in Richards 2004.

(31)a. *Path*

The path between α and β is the nonnull set of nodes x such that α c-commands x and x dominates β .

7) Miyagawa (2004) proposes that the EPP feature never functions in isolation but rather necessarily occurs in tandem with either agreement or focus. Here I follow Miyagawa's (2001) view that scrambling is induced by an EPP feature that works in isolation, without agreement.

b. *Shortest*

The relation between α and β obeys Shortest iff there is a path π between α and β such that for any γ distinct from both α and β , π is a subset of the path π' created by substituting γ for either α or β .

Richards claims that Shortest derives the effects of two locality conditions, Shortest Attract and Shortest Move. If applied to the relation between the attractor and the tail of the chain, Shortest requires the target of attraction to be as close to the attractor as possible; this derives the effects of Shortest Attract. On the other hand, if applied to the relation between the head and the tail of the chain, Shortest requires the chain to be as short as possible, which derives the effects of Shortest Move. Shortest may also apply to the relation between the attractor and the head of the chain. In that case, it forces the landing site of movement to be as close to the attractor as possible. The effects here are also those of Shortest Move.

Let us look at (30) from the point of view of Shortest. In (30) the path between C, the attractor, and the subject is a subset of the path between C and the object (the former is {TP} but the latter contains VP and other nodes in addition to TP), so Shortest requires C to attract the subject *wh*-phrase. Movement of the subject *wh*-phrase to Spec,C yields (32) (I abstract away from irrelevant details).

(32) [CP koj C [TP <koj> vizda kogo]]

Once C has attracted the higher *wh*-phrase, it can attract the lower one without violating Shortest (see Richards 1998 and Hiraiwa 2001 for relevant discussion). So the next step is movement of the object *wh*-phrase to a Spec,C. There are two possibilities here: movement to a higher Spec and movement to a lower Spec. (33) shows these two possibilities.

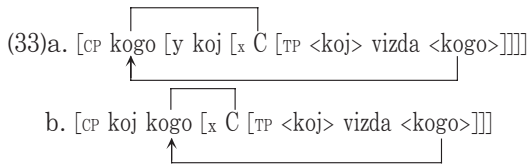

Notice that *kogo* (the head of the chain) is closer to its copy (the tail of the chain) in (33b) than in (33a) since the path between *kogo* and its copy in (33b) is a subset of the path between them in (33a) (the latter path contains *y* but not the former). Therefore, Shortest always forces the second *wh*-phrase to tuck in beneath the first *wh*-phrase, forming a lower Spec,C. The same result is redundantly obtained if we consider the relation between C and *kogo*. The path between them in (33b) is a subset of that in (33a). Here too, Shortest chooses (33b) over (33a).

In multiple *wh*-movement cases (involving two *wh*-phrases) commonly discussed, this is the only result we obtain; that is, the *wh*-phrase moving later always forms a lower Spec,C (except when the *wh*-phrase is D-linked, which we disregard). Since Shortest forces this, there is no optionality here (thus, (30a) is grammatical and (30b) is not). However, Richards (2004) points out an interesting exception to this otherwise general pattern. The

exceptional pattern is seen when one *wh*-phrase is embedded in another. In such cases, optionality arises with respect to the landing site of the embedded *wh*-phrase. The following Bulgarian sentences show this:

- (34)a. [Po kakvo] [kolko studenti of Bulgaria] vidja?
of what how.many students from Bulgaria you.saw
'How many students of what from Bulgaria did you see?'
b. [kolko studenti ot Bulgaria] [po kakvo] vidja?

In these sentences *po kakvo* 'of what' originates in the DP containing *kolko studenti ot Bulgaria* 'how.many students from Bulgaria.' Richards shows carefully that (i) both *po kakvo* and *kolko studenti ot Bulgaria* are in Specs of C, and (ii) *po kakvo* moves to Spec,C after the DP embedding it has first moved to Spec,C. On this analysis, the grammaticality of both examples indicates that *po kakvo* can move either to a higher Spec, (34a), or to a lower Spec, (34b), the latter involving lowering.

Richards (2004) addresses the question of why optionality is permitted in this case, in contrast to standard cases like (30). He first assumes that Bulgarian obeys some version of the A-over-A condition, so that the embedding *wh*-DP must be attracted by C first (he suggests that this also follows from Shortest). If the embedding *wh*-DP moves to Spec,C, the following results:

- (35) [CP [kolko studenti [po kakvo] ot Bulgaria] C [TP vidja <[kolko studenti [po kakvo] ot Bulgaria]>]]

The next step is movement of *po kakvo*. The question is why both (i) and (ii) in (36), where DP* = *po kakvo*, are possible.

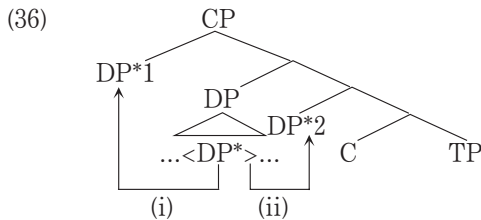

According to Richards, the key is the nature of Shortest. Recall that Shortest derives the effects of Shortest Move, which can be satisfied in one of two ways: it is satisfied if the head of the movement chain is as close to its tail as possible, or if the chain head is as close to the attractor as possible. In standard cases like (30), the two requirements have the same effect, as shown in (33), and hence are redundant. However, Richards argues, this redundancy disappears in the case of (36). If Shortest applies to the relation between DP* and C, it chooses (ii) over (i) since the path between DP*2 and C is a subset of the path between DP*1 and C.⁸⁾ On the other hand, suppose that Shortest applies to the relation between DP* and its copy. In this case, Shortest prefers (i) over (ii). This is because there is no path between DP*2 and <DP*> (there are no nodes c-commanded by either DP*2 or <DP*>, and dominating the other) whereas there is one between DP*1 and <DP*>. As a result, Shortest fails to choose between (i) and (ii). In this situation, Richards claims, both movement

options are permissible, which is the source of optionality in (34).

Richards (2004) thus makes the strong point that the lowering operation in (36), though nonstandard from the point of view of earlier theories, is indeed allowed by UG. This result has a direct impact on the present proposal for complement-forming movement. Relevant here is the fact that Turkish allows both leftward and rightward scrambling. Under the proposal being pursued, this means that the two movement possibilities shown in (37) are both permitted.

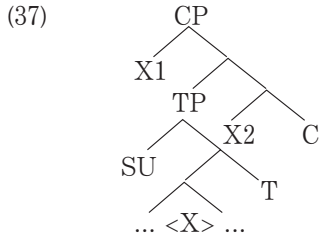

The question is why there is optionality here.

The question receives a straightforward answer if we consider the movements in (37) in the light of Shortest. What is relevant is the landing site of X, so we are dealing with Shortest Move. Recall from the discussion of (36) that if each of the two conditions on Shortest Move prefers a different landing site, we obtain optionality. Consider first the relation between the head and the tail of the chain. Note that just as in the case of (ii) in (36), there is no path between X2 and <X> in (37) (there are no nodes that are c-commanded by either X2 or <X>, and dominate the other). Since there is a path between X1 and <X> in (37), movement to X1 is preferred on this count. What about the other relation, that between the attractor and the head of the chain? Intuitively, X2 is clearly closer to C than X1; in fact, a head and its complement are in the closest possible relation. However, this intuition cannot be maintained under the version of Shortest given in (31) since, according to the definition in (31a), there is no path between X2 and C: there are no nodes c-commanded by X2 or C, and dominating the other.

Note that we understand domination to be irreflexive here (C does not dominate itself, for example). To maintain the intuition that a head and its complement are in the closest possible relation, let us understand domination relevant to the notion of path defined in (31a) as follows:

- (38) Domination is reflexive for nonmaximal minimal projections; it is irreflexive otherwise.

Following Chomsky (1995:242), let us assume that the notions of maximal projection and

8) Richards assumes that any element that is present in the derivational workspace can be the target of agreement/attraction (modulo cyclicity and Shortest Attract). Thus, C can attract DP* even though C does not c-command DP*. In fact, on the basis of the discussion of (34), he concludes that there is no c-command condition on agreement/attraction, contrary to Chomsky's (1995, 2000, 2001) theory. A different issue is why C can attract DP* in (36) without violating Shortest Attract, despite the fact that there is no path between C and DP*. Here Richards (2004:note 6) adopts a proposal of Richards (1998), according to which a head H is immune to Shortest Attract once H has satisfied it. In (36) C satisfied Shortest Attract when it attracted the DP containing DP*, and hence can attract DP* without being regulated by Shortest Attract (see also the discussion of (32)).

minimal projection are defined contextually. Thus, a category is a minimal projection if it is not a projection at all, and is a maximal projection if it does not project any further. According to this conception, X1 and X2 in (37) are maximal since they do not project any further (they may be minimal as well if they are not projections of anything). On the other hand, C in (37) cannot be maximal, given that it projects (up to CP). Since C is not a projection of anything, it is a nonmaximal minimal projection. Therefore, given (38), C dominates itself, whereas X1 and X2 do not. As a result, there is a path between X2 and C: {C}. Since the path between X1 and C contains C and other elements (namely, projections of C excluding CP), Shortest now prefers movement to X2 over movement to X1 in terms of the relation between the chain head and the attractor. Since, at the same time, it prefers movement to X1 over movement to X2 in terms of the relation between the head and the tail of the chain, Shortest fails to choose between the two movements, and both are permitted. Optionality between leftward and rightward scrambling thus follows.

The situation in (37) is exactly the same as that in (36). Thus, complement-forming movement, together with lowering in (36), falls under a class of movements that are nonstandard from the point of view of earlier theories but are nevertheless made available by UG.

An important question arises in this connection. We have seen that in the case of *wh*-movement, movement to a lower Spec, an instance of tucking in, is obligatory. We have also seen that in the case of scrambling, complement-forming movement, another instance of tucking in, is optional. The difference is already accounted for: with *wh*-movement Shortest always prefers the tucking-in option (see (33)), whereas with scrambling Shortest fails to choose between the Spec-forming option and the complement-forming option. So far, so good. The question arises as to why the complement-forming option is not available for *wh*-movement. Notice that if this option were available for *wh*-movement, languages that have overt *wh*-movement would freely move *wh*-phrases both leftward and rightward. This is clearly not the case (English and Bulgarian, for example, have only leftward *wh*-movement). In fact, as stressed by Kayne (1994), overt *wh*-movement is leftward almost universally (Bach 1971). Complement-forming movement should thus be excluded from options for *wh*-movement. Is there a principled reason for this?

I believe there is. Consider (39).

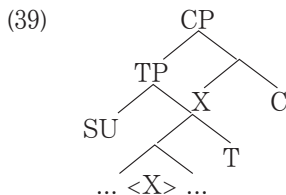

Abstracting away from the order between C and X (which could be opposite in head-initial languages to what is shown in (39)), we see that X does not c-command its copy. Following Richards (2004), we have taken this situation to be unproblematic in terms of derivation. But if X is a *wh*-phrase, it does violate a ban on vacuous quantification, which requires an operator to bind a variable. On the assumption that *wh*-movement is operator movement,

it must form a chain obeying this condition (otherwise, it cannot be interpreted properly). Since complement-forming movement does not serve to form such a chain, it is not an option for *wh*-movement. The same restriction does not apply to scrambling, given that it is nonoperator movement (Saito 1989). The difference between *wh*-movement and scrambling with respect to the possibility of complement-forming movement follows in this way.⁹⁾

Note that this analysis does not exclude movement (ii) in (36). Although DP*2 does not c-command <DP*>, there is a copy of the DP containing <DP*> inside TP (that DP has moved from within TP). And DP*2 can form an operator-variable relation with its TP-internal copy. The crucial difference between movement (ii) in (36) and movement in (39) is that the former is Spec-forming movement, whereas the latter is complement-forming movement. Complement-forming movement never performs *wh*-movement but Spec-forming movement can.

The three concerns with complement-forming movement are thus resolved. In effect, the minimalist theory of phrase structure and movement, coupled with the derivational view of syntactic relations, opens up a new possibility that was impossible in earlier studies. As a result, complement-forming movement is a licit option made available by UG, contrary to appearances.

2.2 Deriving Turkish PVCs

My claim is that scrambling can be carried out by complement-forming movement, and that such complement-forming scrambling results in rightward movement and derives Turkish PVCs. Let us consider in more detail how complement-forming scrambling interacts with the strictly head-final structure in (40).

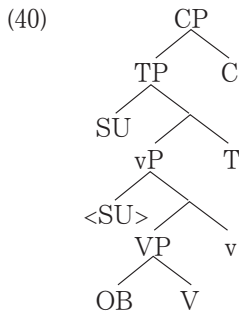

Recall that Kural (1997) claims that V always raises overtly to C in Turkish. We saw in section 1.2 that this claim causes serious problems when we analyze scope facts in verb-final sentences (see the discussion surrounding (14)). On the other hand, arguments that V stay in place have been made for Japanese and Korean, both of which are also head-final languages (see Takano 1996, 2004, Fukui and Takano 1998, Sakai 1998, and Aoyagi 2001 for

9) Questions arise for other kinds of movement. While the present proposal will have nontrivial consequences for their analysis, exploration of those consequences is another topic beyond the scope of this study, and I will leave it for another occasion.

Japanese, and Yoon 1994 for Korean). Here I depart from Kural, and assume that Turkish is the same as Japanese and Korean in not having overt verb raising.

Regarding verbal inflection in Japanese and Korean, the authors just cited follow an analysis of verbal inflection in English proposed by Halle and Marantz (1993), Bobaljik (1994, 1995), and Lasnik (1995b), and argue that V and T (the locus of tense/agreement morphology), though separated in the syntactic derivation, get merged in the phonological component (i.e., in the derivation from Spell-Out to PF) under the condition of adjacency. Let us assume that this analysis holds for Turkish as well. The structure in (40) is associated with a linear string ending with V-v-T-C. Given that V and T must be adjacent in the phonological component, one might wonder how V and T get merged with v intervening between the two. It is reasonable to assume that operations in the phonological component only "see" material with phonetic content. Then the presence of v between V and T does not affect merger of V and T since v has no phonetic content.

On the other hand, the presence of material with phonetic content between V and T does disturb adjacency. This happens when rightward scrambling, analyzed as complement-forming movement, targets T or v. Suppose that the object scrambles and merges with v. This yields the following structure:

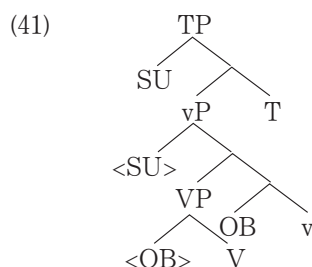

In the phonological component, the scrambled object intervenes between V and T. Since V and T are not adjacent, merger of V and T cannot apply here and the derivation crashes on the PF side: the morphological requirement that T be suffixed to V is not met (see also Kornfilt 1996:118). The same conclusion follows if the object scrambles and merges with T. In this case, too, the object blocks adjacency between V and T.

These considerations show that when complement-forming scrambling takes place, it cannot merge with v or T but must target C. This scrambling yields a surface order in which the scrambled element comes after T and hence does not disturb adjacency between V and T, unlike the previous cases. Recall that C is phonetically null, which ensures that the scrambled element is the final element in the sentence. Thus, on this analysis, Turkish PVCs necessarily move out of TP, as in Kural's (1997) analysis. The important point is, however, that they result from scrambling forming a complement of C, rather than from adjunction to CP.

Recall that we assume, following Miyagawa (2001), that scrambling is driven by an EPP feature optionally assigned to a functional head. The results we have obtained so far indicate that rightward scrambling yields a grammatical output only when C is assigned an

EPP feature. Such an optionally assigned EPP feature functions in isolation (see note 7), in contrast to an EPP feature of T that functions with ϕ -feature agreement (which induces overt movement to Spec,T) and an EPP feature of C that works in conjunction with *wh*-feature agreement. C with an optional EPP feature thus does not enter into an agreement (Agree) relation with anything. On the assumption that Shortest Attract (the effect of Shortest applying to the relation between the attractor and the target of attraction) is a consequence of conditions on agreement (Agree), C with an optional EPP feature can attract any element in the structure. This is why the object can freely scramble to the domain of C in the presence of the subject, which is closer to C.

To make the discussion complete, let us consider how multiple PVCs are derived. Suppose that C has two EPP features. Because of the nature of optional EPP features, C can attract any argument in the sentence. Suppose that it attracts the subject first. This yields (42).

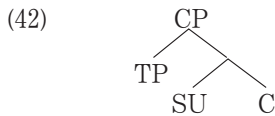

Since C has another EPP feature to be satisfied, it attracts the object. There are two possible landing sites for the scrambled object, as shown in (43).

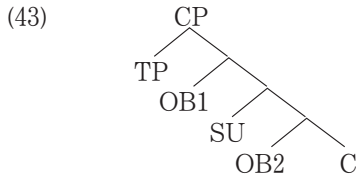

Since neither OB1 nor OB2 c-commands the copy inside TP, no path is defined for either chain. So the choice between OB1 and OB2 is determined solely by Shortest applied to their relation to C. On this count, OB2 is preferred (OB2 and C are in the closest possible relation; see (38)). Therefore, the scrambled object necessarily forms a new complement of C. On the surface, the subject precedes the objects.

The opposite order, both hierarchically and linearly, obtains if the object scrambles first. In general, then, if multiple rightward scrambling occurs, the element that moves later always becomes a new complement of C.

3 Deriving the Properties of Rightward Scrambling

With this proposal, we are now in a position to account for the major properties of rightward scrambling in Turkish summarized in (22) of section 1.2, repeated in (44).

- (44)a. An element that has undergone rightward scrambling necessarily takes scope over preverbal material.
- b. Unlike multiple leftward scrambling, multiple rightward scrambling yields scope ambiguity.
 - c. Unlike leftward scrambling, rightward scrambling is blocked in nominal clauses.

3.1 Rightward Scrambling and Scope

Let us begin with (44a). I will show that this property is tied closely with the conclusion reached in the previous section, namely, that rightward scrambling can only merge with C and not with a lower head.

Let us first clarify the mechanisms that are responsible for scope assignments in Turkish.¹⁰⁾ I will assume (45).

- (45)a. QR involves pronunciation of the tail of a chain. (Bobaljik 1995, Fox and Nissenbaum 1999, Groat and O'Neil 1994, Pesetsky 1998)
- b. QR involves Merge (rather than adjunction).
- c. QR is feature-driven and obeys Shortest. (Bruening 2001)
- d. If a QP is in a position where it can bind a variable, it is interpreted as an operator in that position without QR ("QP" is understood to be the head of a chain).

(45a) is one way of accounting for the covert nature of QR. (45b) is consistent with the position adopted here that movement involves Merge. (45c) is argued for by Bruening (2001). I will assume with Bruening (2001) that QR is induced by a formal feature (a QR feature) that is optionally assigned to a functional head. Given feature-based cyclicity, which we adopt here, (45c), together with (45a), ensures that QR occurs in the same cyclic derivation as overt movement. In other words, I do not assume any special derivational component (like the traditional "LF component") where QR takes place. On this view, QR is just like other feature-driven movement, obeying feature-based cyclicity, except that the tail, instead of the head, of the QR chain is pronounced. The idea underlying (45d) is economy: QR is a last resort operation, so that it applies only when necessary to form an operator-variable structure (thus avoiding vacuous quantification and satisfying the principle of Full Interpretation). Under these assumptions, scope relations between QPs are determined by c-command relations holding between them at LF (i.e., after all QR has applied).

Let us turn to the relevant facts discussed in section 1.2, summarized below (see (10)-(12) for concrete examples):

- (46) SU OB V. [SU > OB, *OB > SU]
- (47)a. SU DAT ABL V. [DAT > ABL, *ABL > DAT]
- b. SU ABL DAT V. [ABL > DAT, *DAT > ABL]
- (48) OB SU V. [OB > SU, *SU > OB]
- (49)a. DAT ABL SU V. [DAT > ABL, *ABL > DAT]
- b. ABL DAT SU V. [ABL > DAT, *DAT > ABL]

These facts indicate that, as far as QPs appearing preverbally are concerned, their scope corresponds exactly with their linear order. As Kural (1997) points out, it appears that scope relations between these QPs are determined by their surface positions.

We can give substance to this intuition under the assumptions in (45). Assuming that the nominative subject overtly raises to Spec,T, it follows from (45d) that in both (46) and

10) Although there are languages (e.g., English and Japanese) that show different patterns of scope assignments from Turkish, I remain silent, except for speculative remarks in footnotes, about issues on parametric variation, focusing here on deriving the facts in Turkish.

(48), the QP in Spec,T does not undergo QR. Since it can bind a variable in Spec,v, the base position of the subject, it is interpreted as an operator there, without QR. As a result, the subject takes scope in Spec,T.

Similarly, the object in (48), having undergone scrambling, can bind a variable in its base position without QR, so that it takes scope in the scrambled position, which may be a higher Spec of T (with a lower Spec filled by the subject) if T triggered scrambling, or a Spec of C if C triggered it. Regardless of the exact position of the scrambled object, the scope fact in (48) falls into place: the scope-taking position for the object c-commands the scope-taking position for the subject, yielding the unambiguous wide scope for the object. The same analysis carries over to the cases in (49). In these cases, both QPs have scrambled and they are interpreted in their surface positions, again without QR. Thus, regardless of the exact positions they occupy, the preceding QP c-commands the following QP, which accounts for the scope facts observed.

What about the object in (46)? Since the object in its base position cannot function as an operator binding a variable, QR, as a last resort, must apply in this case.¹¹ By (45c), QR is induced by a QR feature assigned to a functional head. Suppose a QR feature is assigned to *v* (recall that we assume that QR features are assigned to a functional head optionally). In accordance with cyclicity, the QR feature assigned to *v* must be satisfied before *v*P gets merged with T. So *v* attracts the object QP in the *v*P cycle, moving it to Spec,v, as shown in (50) (note that this is QR, so the tail of the chain is pronounced at PF).

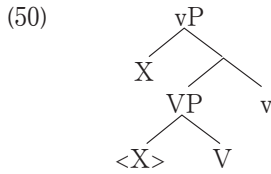

Since X can now bind a variable (its copy <X>), the object QP takes scope in Spec,v. Given that the subject QP takes scope in Spec,T, the unambiguous wide scope for the subject QP in (46) follows.

Note that X cannot merge with *v* here. Such complement-forming QR will yield a configuration where X does not c-command its copy inside VP. The result will thus be uninterpretable (vacuous quantification).

Another possibility is for T to have a QR feature. In this case, T will attract the object QP inside VP and the object QP will move to Spec,T. In fact, the movement will not be carried out in one step. Legate (2003) has shown that there is evidence that movement proceeds phase by phase. If so, the object QP must move via Spec,v. Note that the QP in Spec,v can bind a variable, as in (50). Then further movement of the QP to Spec,T is considered to be an unnecessary step and hence is disallowed by (45d). The same holds if C has a QR feature. In effect, only the derivation where *v* is assigned a QR feature remains valid for the object

11) The particular example in (10a) taken from Kural 1997 has an adjunct between the object and the verb. I assume with Larson (1988, 1990) that the adjunct is base-generated in the complement of V and the object in Spec,V. However, for the sake of discussion, I will ignore the adjunct.

QP staying in VP.

The scope facts in (47) also follow. Suppose that a VP with two internal arguments has the following structure:

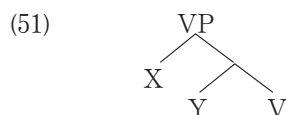

Since neither X nor Y can form an operator-variable structure in their in-situ positions, QR applies to them, moving them to new positions. Let us assume that multiple QR is triggered by multiple QR features, each instance of QR triggered by one QR feature. As in the previous case, *v* is the only candidate for QR features attracting QPs internal to VP. So let us imagine that *v* has two QR features. Given Shortest, *v* attracts X first, moving it to Spec,*v*, and then attracts Y, moving it to a lower Spec,*v* than X. The resulting structure is (52).

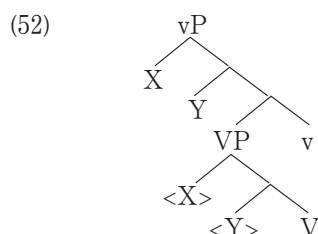

In (52) the c-command relation between X and Y is identical to that between <X> and <Y>. That is, the preceding object asymmetrically c-commands the following one at LF. Thus, the former always takes scope over the latter.¹²⁾

We can see that due to the effects of (45c, d), QR does not create new c-command relations for preverbal QPs. Thus, we can explain why scope relations between preverbal QPs appear to be determined by their surface positions.¹³⁾

While the effects of QR are not dramatic for preverbal QPs, the situation changes with postverbal QPs, given the analysis of Turkish PVCs proposed in section 2. In cases having postverbal QPs, QR does contribute significantly to assigning them scope that cannot simply be derived from their surface positions.

Recall that a PVC unambiguously has wider scope than preverbal material. The relevant examples (in (13)) show the following patterns:

- (53)a. SU V OB. [OB > SU, *SU > OB]
 b. OB V SU. [SU > OB, *OB > SU]

Under the present approach to Turkish PVCs, (53a) has the following structure:

12) The account here is essentially the same as the account that Bruening (2001) offers for scope rigidity effects seen with English double objects (e.g., *I gave a child each doll*, where *a child* unambiguously takes scope over *each doll*).

13) This result may point to a correlation between the availability of overt scrambling and the lack of long QR producing inverse scope. Thus, English lacks overt scrambling but has long QR (thus, *someone met everyone* is ambiguous); Turkish lacks long QR but has overt scrambling, which appears to take on the role of forming operator-variable structures. How this correlation can be derived theoretically is a matter beyond the scope of this article. See also Johnson 2000 for a proposal in which English QR is identified with scrambling in Dutch and German.

(54)

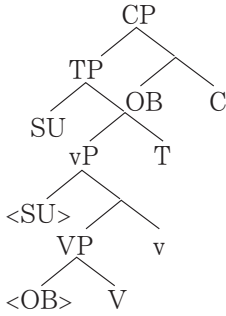

The situation with the subject remains the same as that in (46): due to overt movement to Spec, T, the subject takes scope there.

What about the object? Note that rightward scrambling, by its very nature, does not place the scrambled element in a position that c-commands its copy in θ -position, which will function as a variable. Since it cannot bind a variable from the complement position of C, the scrambled object in (54) cannot function as an operator in that position. To form a legitimate operator-variable structure, QR must apply, moving the object to a position that c-commands the copy in VP. There are a number of possibilities to consider.

Note that QR can never move OB in (54) to a position internal to TP. This is because QR obeys feature-based cyclicity and the derivation has already reached the CP cycle in (54). Thus, only C or a higher head can induce QR of OB.

Suppose a QR feature is assigned to C. C then attracts the object QP. If the object QP moves to a Spec,C higher than TP, the result will be as in (55).

(55)

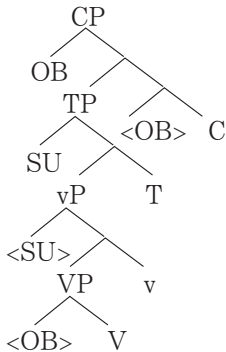

Since the QRed object binds a variable, <OB>, it takes scope in Spec,C. Since Spec, C asymmetrically c-commands Spec,T, the object has scope over the subject and not vice versa.

What happens if the QRed object moves to a Spec,C lower than TP, as in (56)?

(56)

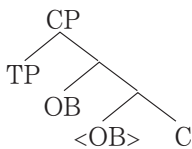

Note that if we look at the relation between the head and the tail of the chain created by QR, movement of the object in (56) is shorter than that in (55). And if we look at the

relation between the head of the chain and C, the attractor, OB is closer to C in (56) than in (55). As a result, Shortest will choose the derivation in (56) over that in (55). Note, however, that the object QP in (56) does not bind a variable (which is internal to TP) and hence induces vacuous quantification. If Shortest should choose the derivation in (56) over the derivation in (55), (53a) could not be grammatical, the wrong result. A solution to the problem will be to assume that satisfaction of operator features must create an operator-variable structure (see also the discussion surrounding (39)). Since the result of QR in (56) does not yield an operator-variable structure, this derivation is not the legitimate way to satisfy the QR feature and hence is not even an option to be evaluated by Shortest. Then the derivation in (55) will be the one meeting Shortest.

For the same reason, the object QP can never undergo complement-forming movement to C to satisfy the QR feature of C, yielding (57).

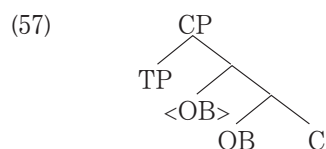

In (55) C is assigned a QR feature. Rizzi (1997) has argued that there are a number of functional projections above TP. If so, it is also possible that a higher functional head has a QR feature.¹⁴ In that case, the following will result:

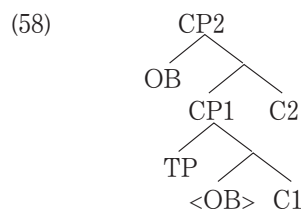

In (58) C1 is the target of rightward scrambling and C2 triggers QR. In this structure, too, the QRed object asymmetrically c-commands the subject, thus accounting for the pattern in (53a).

Let us consider (53b), whose structure is given in (59).

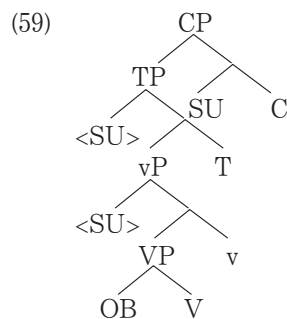

14) I assume that Rizzi's claim that there are a number of functional heads in the so-called CP domain holds constant across languages. It is a separate matter whether those functional projections necessarily host elements of specific semantic content (like focus, topic, etc.), which I leave aside here.

Recall that the object QP in VP can bind a variable if it moves to Spec,v, so that further movement from there is considered unnecessary by (45d). Thus, QR for the object QP must take place in the vP cycle, with v assigned a QR feature. This fixes the scope position of the object QP: it takes scope in Spec,v. For the subject QP, suppose that C has a QR feature and attracts it. Just like the object QP in (55), the subject QP in (59) can move to a Spec,C higher than TP. The structure relevant for scope interpretation is thus (60).

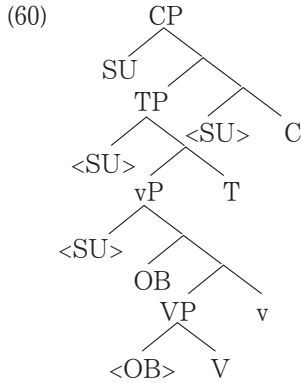

This structure ensures that the subject QP takes scope over the object QP. The same result will be obtained if a functional head higher than C has a QR feature and attracts the subject QP.

Let us imagine that the object QP undergoes leftward scrambling to Spec,C, while the subject QP undergoes rightward scrambling to complement of C. The structure in (61) shows that overt scrambling of the object proceeded by way of Spec,v (Legate 2003).

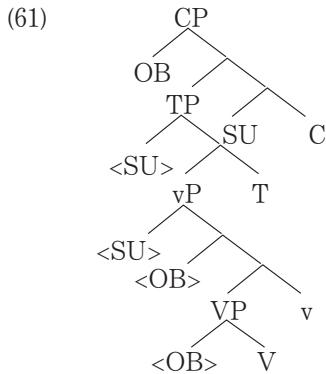

If this derivation were allowed, the object QP would take scope over the subject QP, whose scope-taking position would be a Spec,C lower than the object (due to tucking in), contrary to the fact in (53b). Thus, the overt scrambling of the object in (62) must be excluded. A problem of the same nature will arise in (54) if the subject QP freely scrambles to Spec,C.

Note that the supposed application of scrambling to Spec,C in (54) and (61) does not affect word order. Hoji (1985), Takano (1992), and Abe (1993) have argued that such string-vacuous scrambling be blocked. Takano and Abe have proposed accounts in terms of economy of derivation. In the same spirit, we might appeal to the following idea suggested in

Chomsky 2000, 2001:

(62) Optional operations can apply only if they have an effect on outcome.

Chomsky (2000, 2001) invokes this condition to regulate optional assignment of an EPP feature to the phase head (v, C), which induces overt movement to Spec,C (for successive cyclic movement) or Spec,v (for successive cyclic movement or object shift). Let us generalize (62) to cover scrambling, which is taken here to result from optional assignment of an EPP feature to a functional head. Chomsky (1995:294) suggests that *having an effect on outcome* can be achieved in two ways, either by changing word order or by affecting interpretation, the former being a PF effect and the latter an LF effect. I will assume that what is relevant for scrambling is a PF effect. We then exclude scrambling to Spec,C , due to optional assignment of an EPP feature to C , in (54) and (61) on the grounds that it does not affect word order.

In this way, we can account for the obligatory wide scope of the PVC seen in (53a, b) under the present approach to rightward scrambling. The crucial aspects of this analysis are that rightward scrambling involves complement-forming movement and that the rightward scrambled element necessarily merges with C and not with a lower head. The former aspect captures the asymmetry with respect to scope between preverbal and postverbal elements. Recall that scope assignments for preverbal material in Turkish look like surface phenomena, whereas PVCs constitute an exception. Given condition (45d), the fact that complement-forming movement creates a chain in which the moved element does not c-command its copy in θ -position makes it possible for rightward scrambled elements to undergo QR, though leftward scrambled elements never do. The other aspect of the proposed analysis, that PVCs necessarily merge with C , ensures that, with the help of QR, they always take scope over preverbal material.

That postverbal QPs always have wider scope than preverbal QPs is an important generalization holding for Turkish PVCs, and we have seen that our approach can derive it. However, there are exceptions to this generalization. Before closing this subsection, I will consider two such exceptions.

The first exception is the fact that a PVC can take both wider and narrower scope than an element moved leftward. Kural (1997) points out that the examples in (63) are ambiguous.

(63)a. Uç kişi-ye Ahmet sözletmiş her kitap-tan.

three person-Dat Ahmet mentioned every book-Abl

'Ahmet talked to three people about every book.'

b. Her kitap-tan Ahmet sözletmiş üç kişi-ye.

every book-Abl Ahmet mentioned three person-Dat

The present analysis links this ambiguity to the availability of two landing sites for leftward scrambling past the subject. One possibility is that T is assigned an EPP feature, so that the leftward scrambling lands in Spec,T , as shown in (64).

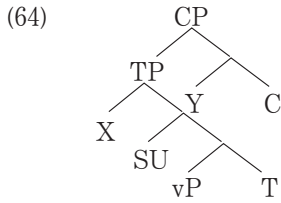

Since the leftward scrambled element X can bind a variable in its base position in VP from the scrambled position, it takes scope there. On the other hand, the PVC Y, not c-commanding its base position, undergoes QR, moving to a higher Spec,C. This derivation gives rise to wide scope for the PVC.

It is also possible that C is assigned an EPP feature. In that case, the leftward scrambling in question lands in Spec,C, as in (65).

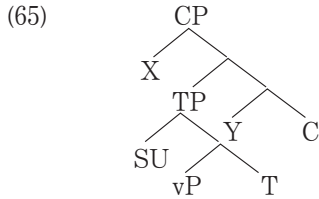

As in the previous case, X takes scope in the scrambled position and Y undergoes QR. However, in this case, QR must move Y to a lower Spec,C than X because of Shortest. This yields wide scope for the leftward scrambled phrase.

These two possibilities of scope interpretation for the leftward scrambled phrase and the rightward scrambled phrase remain the same if we take a higher C-projection into consideration. Thus, the ambiguity of (64) follows from the fact that under the present approach, (64) is associated with two kinds of LF structures each of which accounts for one interpretation.

The second exception to the wide scope of the PVC that we address here has to do with variation in judgments. As mentioned in note 2, the judgments reported by Kural (1997) are not shared by all Turkish speakers. Kornfilt (1996) observes that many speakers, including herself, find the following example, which corresponds to (53a), to be ambiguous:¹⁵⁾

- (66) Herkes bu yıl kitapların-ı ithaf et-miş üç kişi-ye.
 everybody this year books-Acc dedicate-Past three person-Dat
 'This year, everybody dedicated his/her book to three people.'

The wide scope reading for the PVC is derived as shown in (55) and (58). The question is why those speakers can also get the wide scope reading for the preverbal subject.

I suggest that this reading is obtained through reconstruction of the PVC, effected by optional deletion of the head of the chain formed by rightward scrambling. Before deletion

15) Moreover, according to Kornfilt (1996), those who find (66) ambiguous prefer the reading on which the preverbal subject has scope over the PVC. Unlike Kornfilt (1996), Kornfilt (2005) seems to reject the existence of the wide scope reading for the PVC in (66) (see also note 18). These judgments might be captured if in the relevant dialect scope is determined for PVCs either preferentially or exclusively by means of reconstruction. See below for scope-taking by means of reconstruction.

takes place, the (relevant part of the) structure of (66) will be as shown in (67).

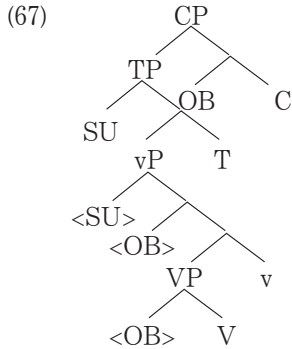

If deletion applies to the head of the chain formed by overt scrambling of the object, OB in the complement of C in (67) will get deleted and the object QP will take scope in Spec,v. Since the subject QP takes scope in Spec,T, the wide scope reading for the subject is derived.

Reconstruction by deletion is in fact available even for Kural's (1997) dialect. Kural points out that the postverbal QP necessarily takes scope under reconstruction when it contains a bound pronoun, as in (68).

- (68) Herkesi dün aramış [proj üç akrabas n]-ı.
 everyone yesterday called three relative-Acc
 'Everyone_i called three of his_i relatives yesterday.'

Recall that in Kural's judgments, the PVC unambiguously takes scope over the preverbal QP. However, according to Kural, the example in (68) permits only a narrow scope reading for the PVC.¹⁶⁾ To account for this fact, Kural proposes that a QP reconstructs only if it is required to do so for independent reasons. This shows that while both Kural's and Kornfilt's dialects allow reconstruction, they differ in how easily they allow it. While scope-taking by reconstruction is restricted to cases like (68) in Kural's dialect, it is more readily available in Kornfilt's dialect.

How readily available is reconstruction in Kornfilt's dialect? Interestingly, it is not a free option. Recall that Kural (1997) reports that leftward scrambling never induces scope ambiguity, with the preceding QP always taking scope over the following QP. Kornfilt (1996) (as well as Kornfilt (2005)) agrees with Kural on this point, observing that the example in (69) is unambiguous, allowing only a wide scope reading of *üç kişi* 'three person.'

- (69) üç kişi-ye herkes kitaplar n-ı ithaf et-miş bu yıl.
 three person-Dat everybody books-Acc dedicate-Past this year

Note that (69) is a word order variant of (66): *üç kişi-ye*, which is postposed in (66), has now undergone leftward scrambling past the subject in (69). The fact that (69) is unambiguous shows clearly that reconstruction is not freely available even in Kornfilt's dialect.¹⁷⁾

16) Thus, this fact constitutes a third exception to the generalization about the scope of the PVC.

17) This is where Turkish differs from Japanese. In Japanese, leftward scrambling does induce scope ambiguity, as pointed out by Kuroda (1970) and extensively discussed by Hoji (1985). Thus, Japanese equivalents of (69) are ambiguous. We might take this fact to be an indication that Japanese differs from Turkish in that it allows scrambled QPs to freely take scope through reconstruction.

Note that the difference between (66) and (69) cannot be derived under the rightward adjunction approach to Turkish PVCs. In particular, it is not clear at all why reconstruction becomes available when a QP is adjoined rightward.¹⁸⁾ Under the present approach, by contrast, the asymmetry in reconstruction between leftward and rightward scrambling receives a simple account. Suppose that Kural's (1997) intuition is correct, in that reconstruction by deletion applies only when necessary. In (69) deletion is unnecessary for either of the QPs: both the subject QP and the object (scrambled) QP can function as operators (they can bind variables) in their surface positions and hence take scope there. In (66) the situation is different. The object QP in (67), occupying the complement position of C, cannot function as an operator in its surface position. For the sentence to receive an interpretation, something must happen to the object QP. One possibility is QR, an option available in both Kural's and Kornfilt's dialects. Another option is deletion and this is available only in Kornfilt's dialect (unless the PVC contains a bound pronoun, in which case it is a valid option in Kural's dialect, too). The present approach thus provides an insight into the nature of the scope patterns reported by Kornfilt (1996) as well.¹⁹⁾

3.2 Multiple Rightward Scrambling and Scope

Let us move on to the property in (44b), that multiple rightward scrambling of QPs yields scope ambiguity, in contrast to multiple leftward scrambling, which never yields ambiguity. I will show that this property also follows easily under the present approach.

The examples of relevance are those in (15) and (17) in section 1.2, which exhibit the patterns in (70) and (71), respectively.

- (70)a. V SU OB. [SU > OB, OB > SU]
- b. V OB SU. [SU > OB, OB > SU]
- (71)a. SU V DAT ABL. [DAT > ABL, ABL > DAT]
- b. SU V ABL DAT. [ABL > DAT, DAT > ABL]

Under the present approach to rightward scrambling, these examples receive the following analysis:

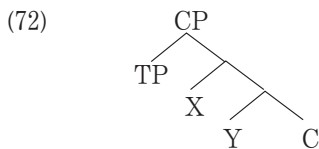

X and Y are the elements that have undergone rightward scrambling, and X precedes Y.

18) Kornfilt (1996) does not offer an account of this difference. Kornfilt (2005) claims that QPs as PVCs are always interpreted under reconstruction, though she does not address the question of why this should be the case.

19) Kornfilt (1996) also observes that the sentence in (i), another word order variant of (66), is ambiguous.
 (i) Herkes bu yıl kitapların-ı üç kişi-ye ithaf et-miş.
 everybody this year books-Acc three person-Dat dedicate-Past

The fact that the dative object can take wider scope than the subject contrasts with what is reported by Kural (1997) for scope patterns of preverbal QPs. Kornfilt (1996:note 2) mentions that the wide scope of the dative object in (i) might result from focalization (the immediately preverbal element is an unmarked focus in Turkish). If so, the focalized element acquires wide scope by means of mechanisms other than QR.

Since neither X nor Y c-commands into TP, which contains their base positions, both elements need to move via QR. Suppose C is assigned QR features and attracts X and Y. Given that Y is closer to C than X, Shortest Attract requires Y to be attracted first. After Y moves to a Spec, C higher than TP, X undergoes QR (due to attraction by C) and tucks in beneath X. The results of these QR operations will thus be as in (73).

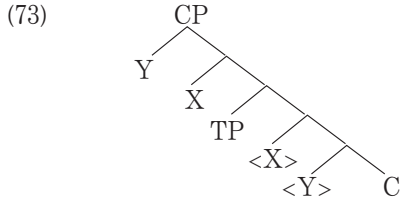

In this structure, Y unambiguously takes wider scope.

As before, it is possible that a higher functional head has QR features. In that case, X is closer to this head than Y, so X undergoes QR first this time. After that, Y undergoes QR, tucking in beneath X. Thus, the result exactly opposite to (73) will be derived:

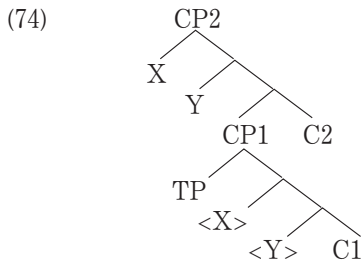

Although other derivational possibilities exist for X and Y, the availability of these two derivations from (72) is sufficient to account for the observed ambiguity in (70) and (71). What plays an important role here is again the analysis of rightward scrambling as complement-forming movement and the assumption that QR is feature-driven and subject to Shortest.

Importantly, the same situation never arises for multiple leftward scrambling. Leftward scrambled elements necessarily occupy Spec,T or Spec,C. Thus, if two internal arguments scramble leftward, they occupy two of the Spec positions W through Z shown below:

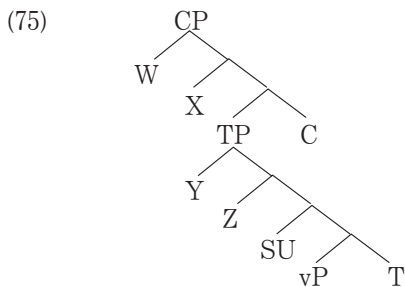

In this situation, it is always the case that the preceding Spec asymmetrically c-commands the following Spec. As we have already seen, leftward scrambled elements never undergo QR and they take scope in their landing sites. Therefore, ambiguity never arises in (76), repeated from (49).

(76)a. DAT ABL SU V. [DAT > ABL, *ABL > DAT]

b. ABL DAT SU V. [ABL > DAT, *DAT > ABL]

Recall that the contrast between (70) and (71) on the one hand and (76) on the other poses a serious problem for the rightward adjunction approach. By contrast, it follows straightforwardly under the present approach.²⁰⁾

3.3 Rightward Scrambling in Embedded Clauses

Finally, let us deal with the structural restriction in (44c), that rightward scrambling is blocked in nominal clauses. The fact that rightward scrambling is possible in embedded clauses that are not nominal (see (19b) in section 1.2 for the example) follows straightforwardly. In such cases, the PVC occurs in the complement of the embedded C, as shown in (77).

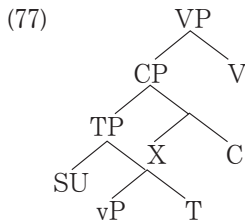

Nothing is wrong with this structure.

On the other hand, if the embedded complement clause is nominal, rightward scrambling internal to the embedded clause is blocked (the relevant examples are in (18c) and (19a)). I propose that this is the same effect that is seen in cases where rightward scrambling merges with T or v. Recall that when rightward scrambling merges with T or v, the scrambled element intervenes between V and T, which makes the bound morpheme located in T unable to merge with V in the phonological component. Recall also that nominal clauses have a Case particle suffixed to the nominalized verb. Case particles are bound morphemes and must attach to a nominal head. Let us assume that in nominal clauses, T has a nominal feature (and is the locus of the nominalization morpheme). Then the head to which a Case particle attaches in nominal clauses is nominal T. Let us also assume that C is the locus of the Case particle. As in the case of T and V, C and nominal T are separated in the syntactic derivation and get merged in the phonological component under adjacency.

Now let us consider what happens when a scrambled element merges with C in a nomi-

20) Kornfilt (2005) also attempts to derive the difference in scope interpretation between leftward and rightward scrambling in Turkish. She pursues the same basic idea as the present approach that something special happens to PVCs, but departs from the latter in technical implementation. She suggests that at Spell-Out the postverbal structure undergoes some kind of linearization process that eliminates hierarchical relations among PVCs. Since her analysis is not fully spelled out, it is not clear exactly how this can be done. See also note 18.

nal clause, as in (77). By assumption, C containing a Case particle needs to be merged with (nominal) T in the phonological component. But X exists between the two as a result of complement-forming scrambling. This prevents the Case particle in C from satisfying the requirement that it be suffixed to T. Therefore, scrambling merging with C is impossible when the clause is nominal.

There is another possibility that has to be excluded. Imagine that an element merges with the matrix V. This will give rise to the following structure:

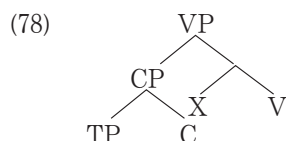

This structure is associated with the order in which the scrambled element X occurs between C and the matrix V. Unlike the previous situation, this situation cannot be excluded for reasons having to do with C, for here X does not intervene between T and C. One possibility that comes to mind is that scrambling of X in (78) is barred by a principle that prevents scrambling out of a CP from landing in the domain of V. The necessity of a principle of this kind has been argued for by Murasugi and Saito (1994) and Saito (1994) on the basis of Japanese examples like (79).

- (79) ??John-ga sono hon-oj Bill-ni [Mary-ga t_j motteiru to] itta.
 John-Nom that book-Acc Bill-Dat Mary-Nom have that said
 'John told Bill that Mary had the book.'

In (79) the scrambled phrase appears between the matrix subject and the dative object of the matrix verb. Taking the landing site of the scrambled phrase to be a VP-adjoined position, Murasugi and Saito (1994) and Saito (1994) propose that scrambling out of a CP is an instance of improper movement if it lands in the domain of V. In fact, Turkish equivalents of (79) are deviant, too (under neutral intonation):²¹⁾

- (80) *Ahmet kitab-ıj Ayşe-ye [Mehmet-in t_j yırttıgın]-ı söyledi.
 Ahmet book-Acc Ayşe-Dat Mehmet-Gen tear-Acc told
 'Ahmet told Ayşe that Mehmet tore the book.'

Thus, we might treat scrambling of X in (78) on a par with scrambling of the embedded object in (70) and (80).

Alternatively, scrambling of X in (78) can be blocked if scrambling is feature-driven. Recall that we adopt Miyagawa's (2001) proposal that scrambling is driven by an optional EPP feature. An EPP feature is a formal feature. Since only functional heads can have formal features, it follows that the lexical verb can never trigger scrambling and that scrambling of X in (78) cannot take place.

We have seen that PVCs within nominal clauses are blocked since rightward scrambling cannot merge with C containing a Case particle. Notice that we must also ensure that

21) Thanks to Cem Keskin for pointing out this fact to me.

rightward scrambling cannot merge with T or *v* in nominal clauses, as it cannot in tensed clauses. The desired result can be obtained if nominal T (which has the nominal feature) is the locus of the nominalization (and agreement) morpheme. In fact, Kornfilt (1997:46) observes that this morpheme occupies the position that corresponds to the tense morpheme in finite clauses. Given that the nominalization morpheme in T must be suffixed to V in the phonological component in the same way that the tense (and agreement) morpheme in finite T is suffixed to V, it follows that scrambling cannot merge with T or *v* in nominal clauses without causing a violation of the morphological requirement that nominal T be merged with V.

Kornfilt (1996) points out that rightward scrambling is possible inside adjunct clauses even though the clauses are of the nominalized variety. One relevant example she gives is the following (see also Erguvanlı 1984):

- (81) ?Hasan_i [proj herkes-ten önce t_j bitirdiği için] işin-ij erkenden ev-den
 Hasan everybody-Abl before finish because work-Acc early home-Abl
 çık-abil-di.
 emerge-can-Past
 'Because he finished his work before anybody else, Hasan was able to leave home early.'

At first sight, this example appears to stand as a problem for the generalization that rightward scrambling is impossible in nominal clauses. In fact, Kornfilt (1996) claims that the acceptability of examples like this favors her own analysis of the restriction on embedded PVCs in terms of the condition that adjunction is possible only to nonarguments. On this analysis, the PVC in (81) is adjoined to an adjunct PP, meeting the condition on adjunction. However, not only does this analysis leave open the question of why adjunction to arguments is disallowed, but its reliance on rightward adjunction is also problematic, as we have already seen.

The example in (81) can be accounted for under the analysis being pursued here. Note that in this case, the PVC (which is an object of the adjunct clause) appears immediately following the element heading the adjunct clause. Following Kornfilt (1996), let us assume that *için* 'because' is a P taking a clausal complement. We can then account for the acceptable status of (81) by assigning the adpositional phrase a structure in which PP is a complement of a functional head (which I call *p* here), in keeping with suggestions by Riemsdijk (1990), Koopman (1993), Baker (1996), and Takano (1996). The adjunct clause in (81) will then have the following structure:

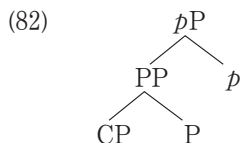

P is the locus of *için*, and *p* is phonetically null. On this analysis, the example in (81) involves merger of the relevant object with *p*. This should be permitted since *p* is by

assumption not a bound morpheme.

Kornfilt (1996) also points out that the following is possible:

- (83) [t_i [alkol-ü bırak-ınca] yemek yemeğ-e başla-dı Hasan_i diye] biliyordum.
 alcohol-Acc leave-when food eat-Dat begin-Past Hasan saying knew
 'I believed that when Hasan stopped drinking, he started eating.'

In this sentence, the subject of the embedded complement clause *Hasan* appears between the verb of the embedded clause *başla-dı* 'begin-Past' and *diye*, which is a word derived from the verb *de* 'say.' Kornfilt suggests that *diye* is a complementizer. If so, this sentence would be analyzed as involving (scrambling and) merger of *Hasan* with the embedded C, where *diye* is located. Under the present analysis, this is possible because *diye* is a free morpheme.

In contrast to the example in (83), the example in (84) is ungrammatical, according to Kornfilt (1996).

- (84) *[t_i [alkol-ü bırak-ınca] yemek yemeğ-e başla-dı diye] Hasan_i biliyordum.
 alcohol-Acc leave-when food eat-Dat begin-Past saying Hasan knew

This example contrasts minimally with that in (83) in that it has the embedded subject after *diye*. Kornfilt claims that the contrast between (83) and (84) follows from the restriction of adjunction to nonarguments (for Kornfilt, (83) involves adjunction to TP and (84) adjunction to CP). Under the present analysis, we again do not need that stipulation. The PVC in (84) is impossible because scrambling of *Hasan* cannot take place. For *Hasan* to appear between *diye* and the matrix V, *Hasan* must merge with the matrix V. But that is impossible, either because this scrambling is improper movement or because the matrix V, being lexical, cannot have an EPP feature triggering scrambling (recall the discussion of (78)).

Finally, let us consider the following example also discussed by Kornfilt (1996):

- (85) *İçki-yi bıraktık-tan beri Hasan [t_i yer] yemeğ-in-i ol-du.
 drink-Acc leave-Abl since Hasan eat food-Acc become-Past
 'Since he stopped drinking, Hasan has been eating his food.'

Assuming the bracketed part of (85) to be a VP, Kornfilt claims that this example shows that adjunction to VP is impossible. (85) can be excluded in our approach, too. Note that unlike the cases in (78) and (84), this case does not seem to involve improper movement (if Kornfilt's assumption that the bracketed part is a VP is correct, this case does not involve movement out of a CP). However, if the bracketed part is a VP, that VP is a complement of the higher verb *ol* 'become' prior to scrambling of *yemeğ-in-i* 'food-Acc.' To appear between *yer* and *ol-du*, then, *yemeğ-in-i* must merge with the higher verb, which is impossible, given that only functional heads can have an EPP feature.

As we have seen in this section, the three properties of Turkish PVCs listed in (44), as well as other properties, all fall into place under the present approach. Recalling that the rightward adjunction approach cannot properly account for them, we conclude that the analysis proposed here is superior to the earlier approach.

4 Apparent Cases of PVCs in Nominal Clauses

In section 3.3, we derived the property of embedded PVCs being blocked in nominal clauses. Aygen (2002:243-244) proposes a different generalization about embedded PVCs. She challenges the traditional observation that PVCs are not allowed in nominal clauses, pointing out that a PVC is possible in a nominal clause if the PVC and the nominal clause are morphologically marked with different cases. According to Aygen, while the sentence in (86) is unacceptable, those in (87) are acceptable, though they all have a PVC in a nominal clause.

(86) *Ben [Ali-nin t_j kırđıĝn]₋₁ cam-ıj sanıyodum.

I Ali-Gen break-Acc glass-Acc thought
'I thought that Ali broke the glass.'

(87)a. Ben [t_j cam-ı kırđıĝn]₋₁ Ali-ninı sanıyodum.

I glass-Acc break-Acc Ali-Gen thought
'I thought that Ali broke the glass.'

b. Ben [Ali-nin t_j kırđıĝn]-a cam-ıj inanyorum.

I Ali-Gen break-Dat glass-Acc believe
'I believe that Ali broke the glass.'

The crucial difference between (86) and (87), according to Aygen, is the fact that while the PVC and the embedded clause are marked with the same (accusative) case in the former, they are marked with different cases in the latter.

Adopting the rightward adjunction approach to Turkish PVCs, Aygen (2002) proposes the new generalization in (88) about embedded PVCs.

(88) Arguments cannot be scrambled out of clauses with the same case morphology.

Although this is consistent with the facts in (86) and (87), it faces a problem, given the example in (89), which Aygen herself judges grammatical.

(89) Kek-ıj Ali [Ercan-ın t_j acele yediĝin]-i söyledi.

cake-Acc Ali Ercan-Gen in.a.hurry eat-Acc said
'Ali said that Ercan ate the case in a hurry.'

In this example, the embedded object with accusative case moves out of the embedded clause that has accusative case, in violation of the generalization in (88). Thus, it would be better to account for the judgments in (86) and (87) without relying on (88).

Kural (1997:note 5) observes that although PVCs in embedded (nominal) clauses are unacceptable with neutral intonation, they become acceptable if the embedded clauses are assigned contrastive focus. I suspect that the reported grammaticality of (87) is due to this effect, namely, focalization of the embedded clause.²²⁾ Kural (1997:note 5) suggests that when the embedded clause is focalized, the PVC is not derived by rightward scrambling. More specifically, he suggests that in that situation, the PVC is derived by leftward scrambling of the PVC followed by leftward focus movement of the embedded clause. Since no rightward scrambling is involved in this derivation, the examples in (87) are grammatical; on our analysis, they do not cause the problems we have seen in (77) and (78).

If so, the relevant question is why (86) is still ungrammatical. On Kural's analysis just

mentioned, (86) will be derived as shown in (90).

- (90) I [Ali-Gen glass-Acc break]-Acc thought
 ↓
 1st step: leftward scrambling of the embedded object
 ↓
 I glass-Acc_i [Ali-Gen t_j break]-Acc thought
 ↓
 2nd step: leftward focus movement of the embedded clause
 ↓
 I [Ali-Gen t_j break]-Acc_j glass-Acc_i t_j thought

The first step, scrambling of the embedded object, should not be wrong, given the grammaticality of (89). Then something must be wrong with the second step. Here we see that the embedded clause with accusative case moves past the embedded object with accusative case. I suggest that movement of this kind causes a problem. In fact, slightly modifying a proposal by Karimi (1999), Aygen (2002:248) suggests (91).

(91) Scrambling of X past Y is illicit if X and Y have the same morphological case.

To motivate this generalization, Aygen provides the following contrast in Turkish:

- (92)a. Ercan-_{i_j} Ali [t_j kek-i yedi] san_ıyor.
 Ercan-Acc Ali cake-Acc ate think
 'Ali considers Ercan to have eaten the cake.'
 b. *Kek-_{i_j} Ali [Ercan-_ı t_j yedi] san_ıyor.
 cake-Acc Ali Ercan-Acc ate think

Aygen argues that the ungrammaticality of (92b) is due to the fact that the accusative object scrambles past the accusative (ECM) subject.

While Aygen's generalization is restricted to scrambling, suppose that we extend it to cover focus movement of the kind seen in the second step of (90). Then the ungrammaticality of (86) follows from the fact that the second step of (90) involves movement of an accusative clause past an accusative object. (86) can now be treated on a par with (92b).

5 Conclusion

I have proposed a new approach to rightward scrambling. At the core of my proposal is the claim that UG permits complement-forming movement, a movement operation in which a moved element merges with a head to form its complement. I have argued that complement-forming movement is an instance of the tucking-in operation à la Richards (1997, 2001) and derives rightward scrambling. I have shown that this approach to rightward scrambling, applied to head-final structure and coupled with independently motivated principles and assumptions, explains a wide range of properties of postverbal constituents in Turkish, including those that have remained unexplained under traditional analyses ap-

22) Cem Keskin informed me that (87a, b) are unacceptable to him unless *cam-in* (87a) and *Ali-nin* in (87b) are stressed.

peeling to rightward adjunction. These achievements constitute a strong argument for the theory of phrase structure that makes complement-forming movement, instead of rightward adjunction, available to derive rightward scrambling.

References

- Abe, Jun. 1993. Binding conditions and scrambling without A/A' distinction. Doctoral dissertation, University of Connecticut, Storrs.
- Aoyagi, Hiroshi. 2001. Nihongo ni okeru zyutugo to ziseiyooso no kootyaku ni tuite. *In Academia: Literature and language* 70, 1-30. Nanzan University, Nagoya.
- Aygen, Nigar Gülşat. 2002. Finiteness, Case and clausal architecture. Doctoral dissertation, Harvard University, Cambridge, Mass.
- Bach, Emmon. 1971. Questions. *Linguistic Inquiry* 2:153-166.
- Baker, Mark. 1996. *The polysynthesis parameter*. New York: Oxford University Press.
- Bobaljik, Jonathan. 1994. What does adjacency do? In *The morphology-syntax connection*, ed. by Heidi Harley and Colin Phillips, 1-32. MIT Working Papers in Linguistics 22. Cambridge, Mass.: MIT, Department of Linguistics and Philosophy, MITWPL.
- Bobaljik, Jonathan. 1995. Morphosyntax: The syntax of verbal inflection. Doctoral dissertation, MIT, Cambridge, Mass.
- Bošković, Željko. 1994. D-Structure, θ -Criterion, and movement into θ -positions. *Linguistic Analysis* 24:247-286.
- Bošković, Željko. 1997. On certain violations of the Superiority Condition, AgrO, and economy of derivation. *Journal of Linguistics* 33:227-254.
- Bošković, Željko. 1999. On multiple feature checking: Multiple *wh*-fronting and multiple head movement. In *Working minimalism*, ed. by Samuel David Epstein and Norbert Hornstein, 159-188. Cambridge, Mass.: MIT Press.
- Bošković, Željko, and Daiko Takahashi. 1998. Scrambling and Last Resort. *Linguistic Inquiry* 29:347-366.
- Bruening, Benjamin. 2001. QR obeys superiority: Frozen scope and ACD. *Linguistic Inquiry* 32:233-273.
- Chomsky, Noam. 1986. *Barriers*. Cambridge, Mass.: MIT Press.
- Chomsky, Noam. 1995. *The Minimalist Program*. Cambridge, Mass.: MIT Press.
- Chomsky, Noam. 2000. Minimalist inquiries: The framework. In *Step by step: Essays on minimalist syntax in honor of Howard Lasnik*, ed. by Roger Martin, David Michaels, and Juan Uriagereka, 89-155. Cambridge, Mass.: MIT Press.
- Chomsky, Noam. 2001. Derivation by phase. In *Ken Hale: A life in language*, ed. by Michael Kenstowicz, 1-52. Cambridge, Mass.: MIT Press.
- Chomsky, Noam. 2005. Three factors in language design. *Linguistic Inquiry* 36:1-22.
- Epstein, Samuel David, Erich M. Groat, Ruriko Kawashima, and Hisatsugu Kitahara. 1998. *A derivational approach to syntactic relations*. New York: Oxford University Press.
- Erguvanli, Eser Emine. 1984. *The function of word order in Turkish grammar*. Berkeley: University of California Press.
- Fiengo, Robert. 1977. On trace theory. *Linguistic Inquiry* 8:35-61.
- Fox, Danny, and Jon Nissenbaum. 1999. Extraposition and scope: A case for overt QR. In *Proceedings of the 18th West Coast Conference on Formal Linguistics*, ed. by Sonya Bird, Andrew Carnie, Jason D. Haugen, and Peter Norquest, 132-144. Somerville: Cascadilla Press.

- Fukui, Naoki. 1993. Parameters and optionality. *Linguistic Inquiry* 24:399-420.
- Fukui, Naoki, and Yuji Takano. 1998. Symmetry in syntax: Merge and Demerge. *Journal of East Asian Linguistics* 7:27-86.
- Groat, Eric, and John O'Neil. 1994. Spell-out at the LF interface. Ms., Harvard University, Cambridge, Mass.
- Halle, Morris, and Alec Marantz. 1993. Distributed Morphology and the pieces of inflection. In *The view from Building 20: Essays in linguistics in honor of Sylvain Bromberger*, ed. Kenneth Hale and Samuel Jay Keyser, 111-176. Cambridge, Mass.: MIT Press.
- Hiraiwa, Ken. 2001. Multiple Agree and the Defective Intervention Constraint in Japanese. In *Proceedings of the 1st HUMIT Student Conference in Language Research (HUMIT 2000)*, ed. by Ora Matushansky, Albert Costa, Javier Martin-Gonzalez, Lence Nathan, and Adam Szczegielniak, 67-80. MIT Working Papers in Linguistics 40. Cambridge, Mass.: MIT, Department of Linguistics and Philosophy, MITWPL.
- Hoji, Hajime. 1985. Logical form constraints and configurational structures in Japanese. Doctoral dissertation, University of Washington.
- Hornstein, Norbert. 1999. Movement and control. *Linguistic Inquiry* 30:69-96.
- Huang, C.-T. James. 1982. Logical relations in Chinese and the theory of grammar. Doctoral dissertation, MIT, Cambridge, Mass.
- Johnson, Kyle. 2000. How far will quantifiers go? In *Step by step: Essays on minimalist syntax in honor of Howard Lasnik*, ed. by Roger Martin, David Michaels, and Juan Uriagereka, 187-210. Cambridge, Mass.: MIT Press.
- Karimi, Simin. 1999. Is scrambling as strange as we think it is? In *Papers on morphology and syntax, cycle one*, ed. by Karlos Arregi, Benjamin Bruening, Cornelia Krause, and Vivian Lin, 159-190. MIT Working Papers in Linguistics 33. Cambridge, Mass.: MIT, Department of Linguistics and Philosophy, MITWPL.
- Kayne, Richard. 1994. *The antisymmetry of syntax*. Cambridge, Mass.: MIT Press.
- Kayne, Richard. 1998. Overt vs. covert movement. *Syntax* 1:128-191.
- Kennelly, Sarah. 1996. Turkish subordination: [-Tense, -CP, +Case]. In *Modern studies in Turkish linguistics*, ed. by Ahmet Konrot, 55-75. Eskişehir: Anadolu University.
- Kitahara, Hisatsugu. 1997. *Elementary operations and optimal derivations*. Cambridge, Mass.: MIT Press.
- Koopman, Hilda. 1993. The structure of Dutch PPs. Ms., University of California, Los Angeles.
- Kornfilt, Jaklin. 1996. On rightward movement in Turkish. In *The Mainz meeting, Proceedings of the seventh international conference on Turkish linguistics*, ed. by Lars Johanson, 107-123. Wiesbaden: Harrassowitz.
- Kornfilt, Jaklin. 1997. *Turkish*. London: Routledge.
- Kornfilt, Jaklin. 2005. Asymmetries between preverbal and postverbal scrambling in Turkish. In *The free word order phenomenon: Its syntactic sources and diversity*, ed. by Joachim Sabel and Mamoru Saito, 163-179. Berlin: Mouton de Gruyter.
- Kural, Murat. 1997. Postverbal constituents in Turkish and the Linear Correspondence Axiom. *Linguistic Inquiry* 28:498-519.
- Kuroda, S.-Y. 1970. Remarks on the notion of subject with reference to words like *also*, *even*, or *only*. In *Part II. Annual Bulletin, Research Institute of Logopedics and Phoniatrics* 4, 127-152. Tokyo: University of Tokyo.
- Larson, Richard. 1988. On the Double Object Construction. *Linguistic Inquiry* 19:335-392.

- Larson, Richard. 1990. Double Objects Revisited: Reply to Jackendoff. *Linguistic Inquiry* 21:589-632.
- Lasnik, Howard. 1995a. A note on pseudo-gapping. In *Papers on minimalist syntax*, ed. by Rob Pensalfini and Hiroyuki Ura, 143-163. MIT Working Papers in Linguistics 27. Cambridge, Mass.: MIT, Department of Linguistics and Philosophy, MITWPL.
- Lasnik, Howard. 1995b. Verbal morphology: *Syntactic structures* meets the Minimalist Program. In *Evolution and revolution in linguistic theory: Essays in honor of Carlos Otero*, ed. Hector Campos and Paula Kempchinsky, 251-275. Washington, DC: Georgetown University Press.
- Legate, Julie Anne. 2003. Some interface properties of the phase. *Linguistic Inquiry* 34:506-516.
- May, Robert. 1977. The grammar of quantification. Doctoral dissertation, MIT, Cambridge, Mass.
- Miyagawa, Shigeru. 2001. The EPP, scrambling, and *wh*-in-situ. In *Ken Hale: A life in language*, ed. by Michael Kenstowicz, 293-338. Cambridge, Mass.: MIT Press.
- Miyagawa, Shigeru. 2004. On the EPP. Ms., MIT, Cambridge, Mass.
- Müller, Gereon. 1996. A constraint on remnant movement. *Natural Language & Linguistic Theory* 14:355-407.
- Müller, Gereon. 1998. *Incomplete category fronting: A derivational approach to remnant movement in German*. Dordrecht: Kluwer.
- Murasugi, Keiko, and Mamoru Saito. 1994. Adjunction and cyclicity. In *Proceedings of the Thirteenth West Coast Conference on Formal Linguistics*, ed. by Raul Aranovich, William Byrne, Susanne Preuss, and Martha Senturia, 302-317. Stanford, Calif.: CSLI Publications.
- Pesetsky, David. 1998. Some optimality principles of sentence pronunciation. In *Is the best good enough?: Optimality and competition in syntax*, ed. by Pilar Barbosa, Danny Fox, Paul Hagstrom, Martha McGinnis, and David Pesetsky, 337-383. Cambridge, Mass.: MIT Press.
- Richards, Norvin. 1997. What moves where when in which language? Doctoral dissertation, MIT, Cambridge, Mass.
- Richards, Norvin. 1998. The Principle of Minimal Compliance. *Linguistic Inquiry* 29:599-629.
- Richards, Norvin. 2001. *Movement in language: Interactions and architectures*. Oxford: Oxford University Press.
- Richards, Norvin. 2004. Against bans on lowering. *Linguistic Inquiry* 35:453-463.
- Riemsdijk, Henk van. 1990. Functional prepositions. In *Unity in diversity: Papers presented to Simon C. Dik on his 50th birthday*, ed. Harm Pinkster and Inge Genee, 229-241. Dordrecht, Foris.
- Rudin, Catherine. 1988. On multiple questions and multiple *wh*-fronting. *Natural Language & Linguistic Theory* 6:445-501.
- Saito, Mamoru. 1985. Some asymmetries in Japanese and their theoretical implications. Doctoral dissertation, MIT, Cambridge, Mass.
- Saito, Mamoru. 1989. Scrambling as semantically vacuous A'-movement. In *Alternative conceptions of phrase structure*, ed. by Mark R. Baltin and Anthony S. Kroch, 182-200. Chicago: University of Chicago Press.
- Saito, Mamoru. 1994. Improper adjunction. In *Formal approaches to Japanese linguistics 1*, ed. by Masatoshi Koizumi and Hiroyuki Ura, 263-293. MIT Working Papers in Linguistics 27. Cambridge, Mass.: MIT, Department of Linguistics and Philosophy, MITWPL.
- Saito, Mamoru. 2003a. A derivational approach to the interpretation of scrambling chains. *Lingua* 113:481-518.
- Saito, Mamoru. 2003b. On the role of selection in the application of Merge. In *NELS 33*, ed. by Makoto Kadowaki and Shigeto Kawahara, 323-345. Amherst: University of Massachusetts, GLSA.
- Saito, Mamoru, and Naoki Fukui. 1998. Order in phrase structure and movement. *Linguistic Inquiry*

29:439-474.

- Saito, Mamoru, and Hiroto Hoshi. 2000. The Japanese light verb construction and the Minimalist Program. In *Step by step: Essays on minimalist syntax in honor of Howard Lasnik* ed. by Roger Martin, David Michaels, and Juan Uriagereka, 261-295. Cambridge, Mass.: MIT Press.
- Sakai, Hiromu. 1998. Feature checking and morphological merger. In *Japanese/ Korean linguistics volume 8*, ed. by David J. Silva, 189-201. Stanford, Calif.: CSLI Publications.
- Sauerland, Uli. 1999. Erasability and interpretation. *Syntax* 2:161-188.
- Takano, Yuji. 1992. Economy of derivation: A view from scrambling. Paper presented at Arizona Linguistic Conference.
- Takano, Yuji. 1994. Unbound traces and indeterminacy of derivation. In *Current topics in English and Japanese*, ed. by Masaru Nakamura, 229-253. Tokyo: Hituzi Syobo.
- Takano, Yuji. 1996. Movement and parametric variation in syntax. Doctoral dissertation, University of California, Irvine.
- Takano, Yuji. 1998. Object Shift and Scrambling. *Natural Language & Linguistic Theory* 16:817-889.
- Takano, Yuji. 2004. Coordination of verbs and two types of verbal inflection. *Linguistic Inquiry* 35:168-178.
- Yoon, James H. 1994. Korean verbal inflection and checking theory. In *The morphology-syntax connection: Papers from the January 1994 MIT Workshop*, ed. by Heidi Harley and Colin Phillips, 251-270. MIT Working Papers in Linguistics 22. Cambridge, Mass.: MIT, Department of Linguistics and Philosophy, MITWPL.